

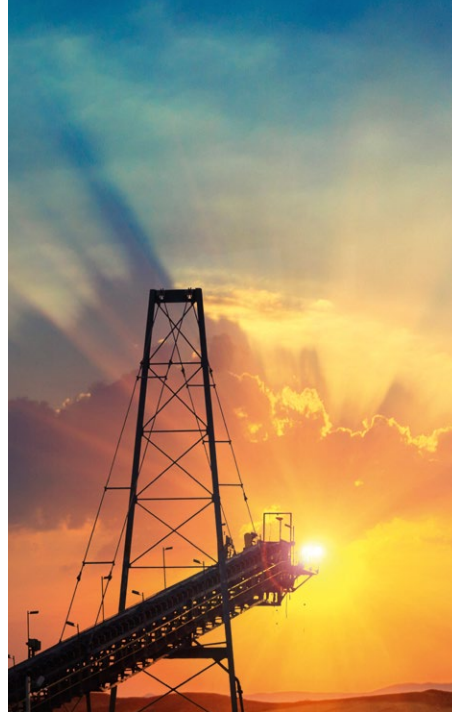

CORREX Material

Processing instructions
for pulley lagging and linings



Contents

- 3 Introduction
- 4 General Instructions
- 5 Tables
- 8 Preparing the Pulley Surface and the Pulley Lagging
- 10 Lining the Pulley - Butt Joint
- 13 Lagging the Pulley - Overlap Joint
- 16 Lagging the Pulley - V-Joint
- 20 Abrasion Protection with CORREX Lining Material



Introduction

Operational readiness, reliability and the working life of any conveying system are all factors which depend on the system being appropriately equipped, serviced and maintained.

The equipment features which contribute most to the operational readiness are those which promote the straight tracking, cleanliness and upkeep of the conveyor belt itself.

Coating some wearing parts with lagging made of specially developed rubber materials with a profiled surface has - over many years of deployment - stood the test of time and contributed to the reliability of the conveyors.

Profiled rubber lagging on the drive pulley increases the co-efficient of friction between the pulley and the conveyor belt, ensuring friction grip even under the most adverse conditions such as moisture and soiling etc.

Moreover, pulley laggings are also used as a protection against both abrasion and noise in those places where surfaces at pick-up points, transfer points and bunkers are particularly vulnerable to attack.

CORREX rubber sheeting with an adhesive layer was designed by Continental for a different arrays of applications.

The numerous technological properties of the rubber materials as well as the wide range of corrugated surfaces combine to cater for the most varied requirements. CORREX adhesive layer rubber sheeting used in conjunction with CONTI PLUS Metal Primer and CONTI SECUR BFA Contact Adhesive with Activator will guarantee high adhesion values, if expertly applied during the cold bonding process.

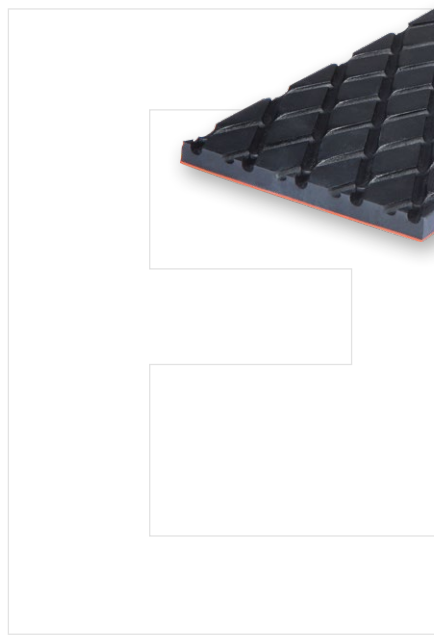
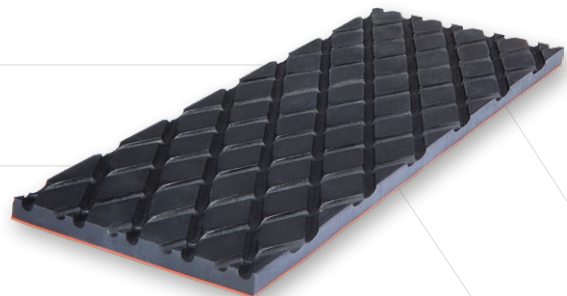

General Instructions

Material, Pulley Lagging and Abrasion Protection

- › suitable for both over- and underground deployment, depending on the individual material.

Storage according to DIN 7716

- › store in a cool, dry and, if possible, dark place
- › recommended storage temperature: approx. 20 °C
- › keep away from oil and grease

Preparing the Bonding Surface and the Sheeting Material

- › remove any rust and dirt by means of sandblasting or sandpapering and clean the surface thoroughly
- › sweep off dry all traces of chippings and dust carefully
- › wash the entire surface with cleaning agent CCS
- › stir the CONTI PLUS Metal Primer thoroughly
- › apply CONTI PLUS to the metal surface, spreading it thinly at a recommended rate of about 100 g/m²
- › allow the coating of CONTI PLUS to dry completely; this requires a minimum of 30 minutes and maximum of one week at room temperature

Attention!

The parts which are coated with bonding agent have to be stored dust-free.

- › mix CONTI SECUR BFA with the activator solution and stir well; the activated cement can be used for 2 to 5 hours, depending on the ambient temperature

Attention!

CONTI PLUS and CONTI SECUR BFA is not authorised for underground use.

- › the following advice must be heeded when working with CONTI SECUR BFA:
 - slightly flammable - do not smoke
 - avoid breathing in the fumes
 - observe the MAC limits (maximum allowable concentration)
 - if the concentration is higher, then wear a breathing mask fitted with A2-filter
- › apply the first coat of CONTI SECUR BFA with a bristle brush thinly
- › let the first coat dry thoroughly
 - Drying time min. 30 minutes (at temperature of 22 - 25 °C)
- › the CORREX material should be cut to the required shape during the first and second applications on the metal surface
- › apply the second coat of CONTI SECUR BFA thinly
 - Drying time: back of the hand test, max. 10 minutes
- › remove the protective foil from the CORREX adhesive layer
- › immediately after the second coating of the metal surface, apply the CONTI SECUR BFA to the adhesive layer thinly
- › allow the adhesive layer coating to dry until.
 - Drying time: back of the hand test, max. 10 minutes

Mounting the Sheet Material

- › when the CONTI SECUR BFA coats on the metal surface and on the adhesive layer of CORREX sheeting are still tacky, lay carefully from inside to outside
- › lay the CORREX lagging by winding it on to the surface and pressing it down so that no air bubbles are trapped underneath

Attention!

Do not pull up the lagging after laying it! If such corrective measures are undertaken - e. g. if the sheet is pulled up - the coat of CONTI SECUR BFA will damage the pulley surface. The damaged area must then be retreated with a single coat of CONTI SECUR BFA.

- Drying time: back of the hand test: max. 10 minutes
- › using a hand roller, press down from the centre outwards
- › finally, the lagging should be hammered flat with a suitable mallet

Commissioning

With cold cements, the adhesion properties increase over a longer period. The conveyor may be put back into service after at least 6 hours without load. For full adhesion under load, a drying time over 12 hours is recommended.

Tables

Recommendations for lagging thickness and material performance for bend, tension and snub drums are dependant on the belt tension.

drum diameter mm	low belt tension		high belt tension	
	lagging	thickness mm	lagging	thickness mm
up to 315	CORREX - approx. 45 Shore A	10	CORREX - approx. 60 Shore A	8
315 - 630	CORREX - approx. 45 Shore A	15	CORREX - approx. 60 Shore A	10
over 630			CORREX - approx. 60 Shore A	12

The recommendation for drive drums lagging thickness is dependant on the drum diameter.

(Profile: Diamond and Mini Diamond)

drum diameter mm	lagging	lagging thickness mm
up to 500	CORREX - approx. 60 Shore A	8
500 - 800	CORREX - approx. 60 Shore A	10
800 - 1000	CORREX - approx. 60 Shore A	12
over 1000	CORREX - approx. 60 Shore A	15

Tables

Comparison of the advantages and disadvantages of different forms of lagging joint.

Joint form	Advantages	Possible Disadvantages
Butt Joint	<ul style="list-style-type: none"> › Application of reversible plant without damage from scraper › Straight forward performance without high expense on time 	<ul style="list-style-type: none"> › With the drum covering based upon Nitrile butadiene caoutchouc › max. 10 mm thickness is recommended › Exact cutting at the joint is necessary to avoid gaps
Overlap Joint	<ul style="list-style-type: none"> › Good security results from the bond between the tacky back and the rubber 	<ul style="list-style-type: none"> › Not possible to run in either direction as damage will result from the scraper › The direction of drum rotation must be given › Direction of the overlap must be noted
V-Joint	<ul style="list-style-type: none"> › Application on reversible plant without damage from the scraper › Feasible with all material thicknesses and application 	<ul style="list-style-type: none"> › Time consuming › Use of additional material necessary

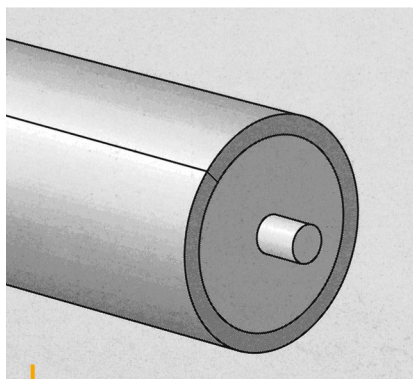

Butt Joint

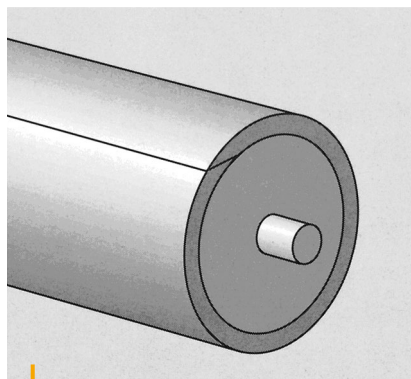

Overlap Joint

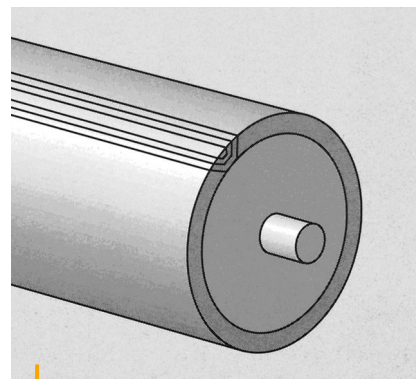

V-Joint

Length increments with Overlap Joints

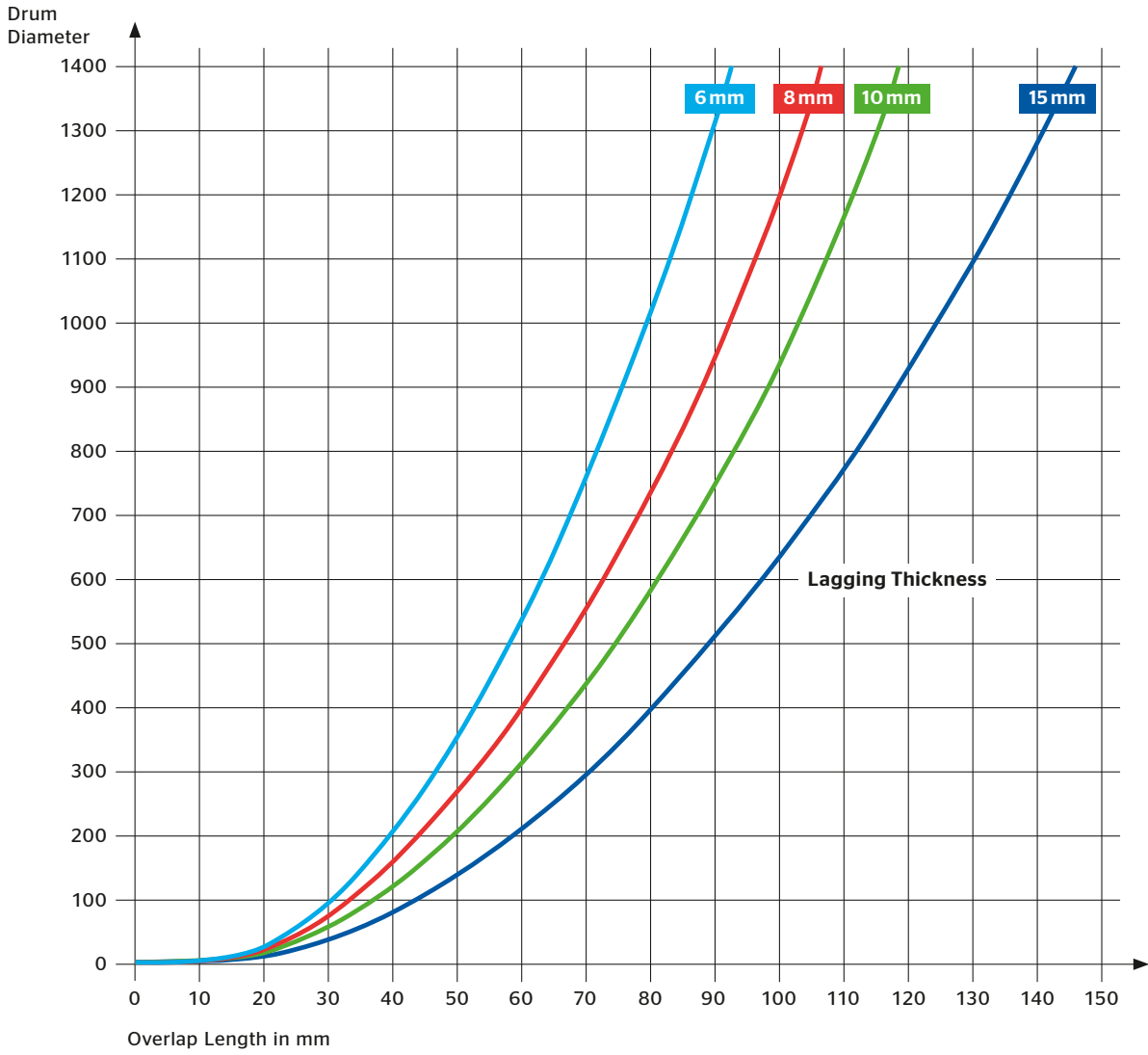

Lagging Length = Pulley Circumference + Overlap Length

Preparing the Pulley Surface and the Pulley Lagging

When the drive, tension and snub pulleys are being lined, three different types of joints can be used:

- › the butt joint
- › the overlap joint
- › the V-joint

Please consult the tables on page 6 for an overview of the various advantages and disadvantages with each type of joint. The work procedures outlined on these two facing pages are the same for all types of joint.

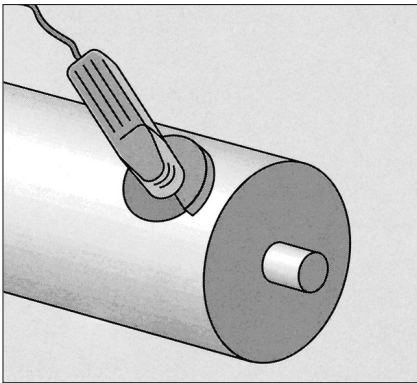

Preparing the Pulley Surface

- › clean the pulley side surfaces and the axes
- › remove all traces of rust by sandblasting or sandpapering (new pulleys should be washed with CCS cleaning agent)
- › brush off dry any chippings or dust
- › wash the pulley cover with CCS cleaning agent

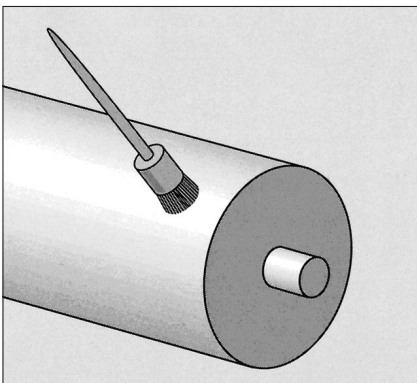

- › stir the CONTI PLUS metal primer thoroughly
- › apply a thin coat of CONTI PLUS to the pulley cover
- › allow CONTI PLUS to dry completely
 - drying time min. 30 mins (at temperature of 22-25 °C)
- › mix CONTI SECUR BFA with the activator solution and stir thoroughly
- › apply the CONTI SECUR BFA to the pulley surface thinly
- › allow the first coat of CONTI SECUR BFA to dry completely
 - drying time min. 30 mins (at temperature of 22-25 °C)

Preparing the Pulley Laggings

- › select the profiled surface and the rubber material
- › calculate the various dimensions, taking type of joint into account

All the other steps are determined by the lagging end joint type chosen.

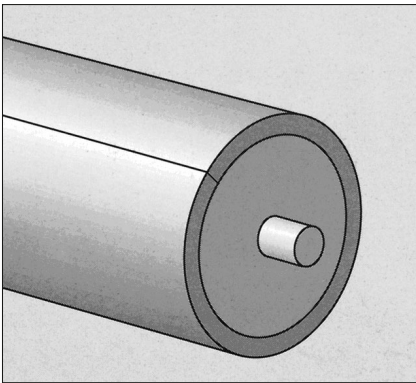

The remaining procedures for the butt joint are described on Pages 10-12.

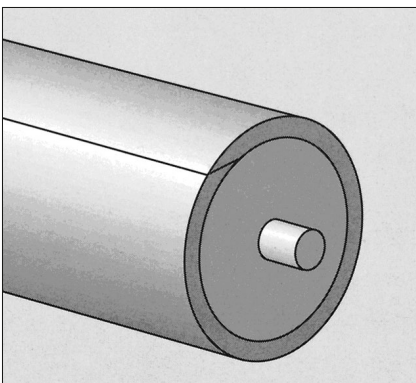

The remaining procedures for the lap joint are described on Pages 13-15.

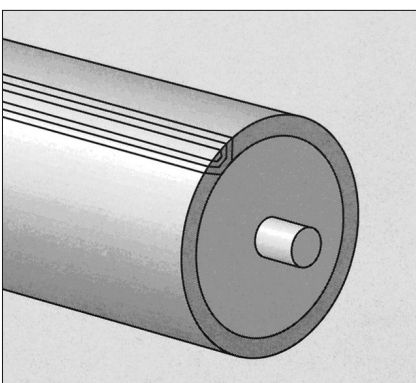

The remaining procedures for the V-joint are described on Pages 16-19.

Lining the Pulley - Butt Joint Type

Attention!

Before the pulley is lined, the steps described on Pages 8 and 9 must be carried out.

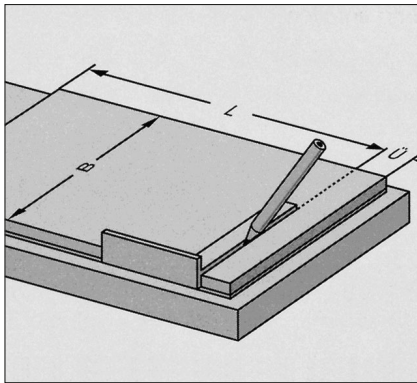

Preparing the Pulley Lagging

- > calculate the dimensions:
lagging width = pulley length + approx. 40 mm
pulley length = (pulley \varnothing + lagging thickness) x 3,14 + splice increment

Example: pulley \varnothing	500 mm	
lagging thickness	10 mm	
	510 mm x 3,14	= 1601 mm
splice increment		+ 40 mm
lagging length		= 1641 mm

- > after calculating the dimensions, cut at right angles
- > roughen a cut edge along the length dimension with a scouring wheel, scraper or rotating wire brush
- > apply a single coat of CONTI SECUR BFA with Activator to the roughened edge

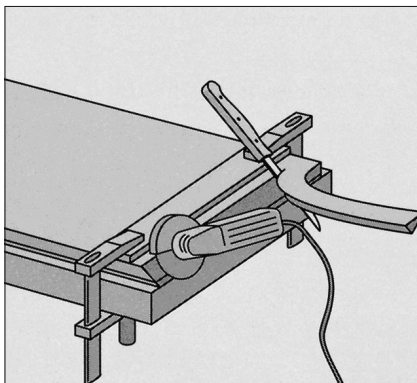

Lagging the Pulley

- > apply a second coat of CONTI SECUR BFA to the pre-prepared pulley cover
- > remove the protective foil from the adhesive layer of the lagging
- > apply CONTI SECUR BFA to the adhesive layer only once and thinly
- > clean the surface of adhesive layer with solvent e.g. CONTI Cleaning Solution - CCS
- > for high adhesion - recommendation is to buff the surface by using a grinder. After that, remove all dust.
- > at the same time, apply a second coat on the cutting edge of the lagging
- > allow the applications on the pulley and the lagging to dry.
→ Drying time: back of the hand test, max. 10 minutes

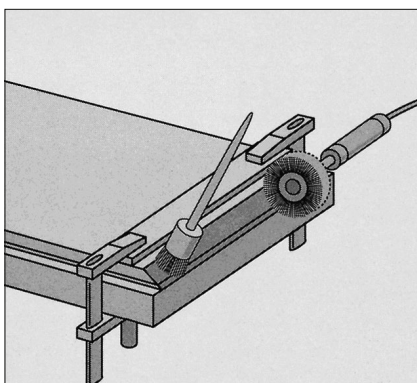

- > lay a try square on the side of the pulley
- > use a scribe to draw a lay-on line across the complete width of the pulley (do not use oil chalk)

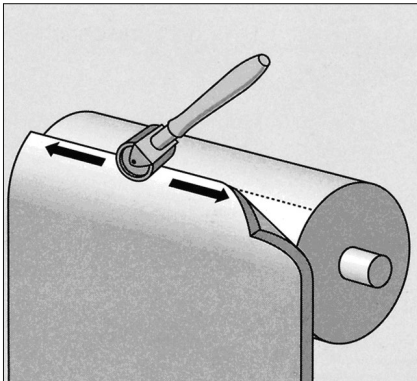

- › place the coated cut edge on the lay-on line with the adhesive layer on the pulley cover, ensuring that the lagging projects over on both sides of the pulley corresponding to the width increment

Attention!

Do not pull the lagging up! If such corrective measures are undertaken - i.e. if the lagging is pulled up - the coating of CONTI SECUR BFA will damage the pulley surface. The damaged area must then be retreated with a single coat of CONTI SECUR BFA.

- Drying time: back of the hand test, max. 10 minutes.
- › wind on the correctly-positioned lagging by manual rolling

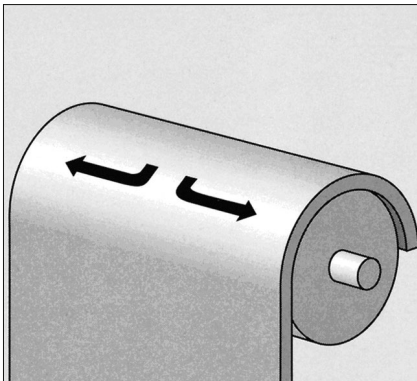

- › whilst continuing to turn the pulley slowly, press down the lagging by sweeping hand movements from the middle towards the edges. Any air bubbles trapped underneath should be pressed out.

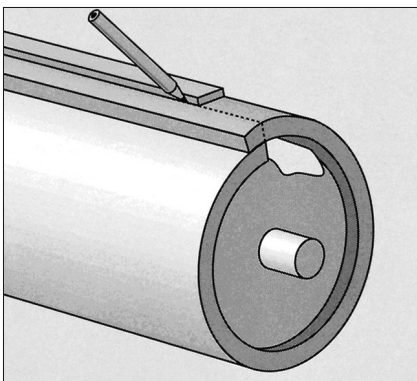

- › place a strip of foil across the complete pulley width in front of the lagging edge first laid on and coated, in order to protect the surface being bonded
- › the end of the lagging sheet now overlaps the positioned lagging edge; the strip of foil hinders any firm adhesion.
- › cast up the cutting line for the lagging end from the lower lagging edge and mark

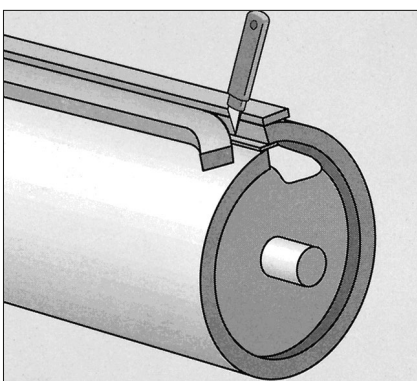

- › push a flat steel rail under the lap
- › place a steel ruler according to the mark
- › cut the lagging along the ruler to length with a sharp knife

NB: The cut should be performed in such a way that a light relief cut is effected in the adhesive layer beneath. This makes sure that the cut edges remain in front of one another and do not expand into a V-shape during the rolling-on above.

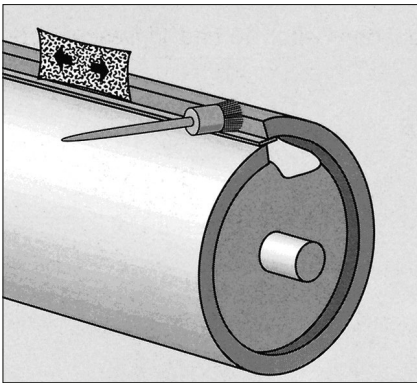

- > roughen the cut edge with a scraper or sandpaper
- > any resultant dust must be removed by dry means
- > apply CONTI SECUR BFA to the cut edge twice
- > when the coats are dry enough, then peel back the strip of foil as far as the middle of the pulley or thereabouts
- > lay the lagging on from underneath and firmly press the two cut edges in front of one another
- > peel the strip of foil further out and fit the lagging further in

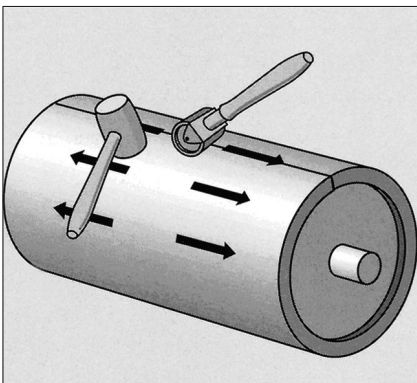

- > pat the lagging down with a motion away from the middle of the pulley. Any air bubbles trapped underneath should be pressed out.
- > with a hand roller, roll the lagging hard from the middle outwards
- > with a narrow serration roller, firmly roll the lagging joint together
- > finally, the lagging should be hammered flat with a suitable mallet

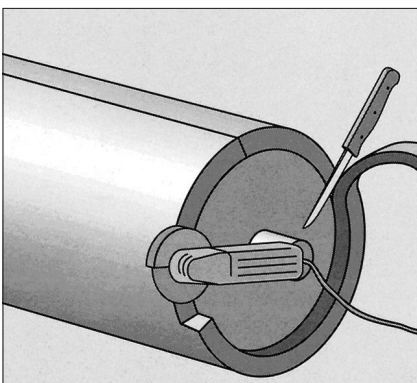

- > cut off the overlapping lagging by a bevel at an angle of approximately 30° to the middle of the pulley
- > using an angle grinder with a maximum of 2000 rpm, grind this angular cut smooth
- > depending on lagging design, also lightly grind the joint smooth and level
- > any resultant dust must be removed by dry means

Lagging the Pulley - Overlap Joint

Attention!

Before the pulley is lined, the steps described on Pages 8 and 9 must be carried out.

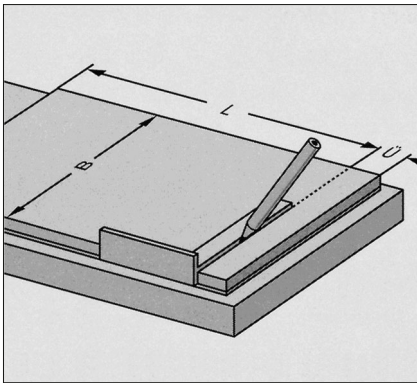

Preparing the Pulley Lagging

- > calculate the dimensions:
lagging width = pulley length + approx. 40 mm
lagging length = (pulley \varnothing + lagging thickness) x 3,14 + splice increment

Example: pulley \varnothing 500 mm
lagging thickness 10 mm
 510 mm x 3,14 = 1601 mm
 overlap + 70 mm
 lagging length = 1671 mm

- > after calculating the dimensions, cut at right angles
- > lay the lagging with the adhesive layer facing downwards on a work top
- > measure the overlap length from a width-side cut edge and mark a line at right angles to the pulley lagging

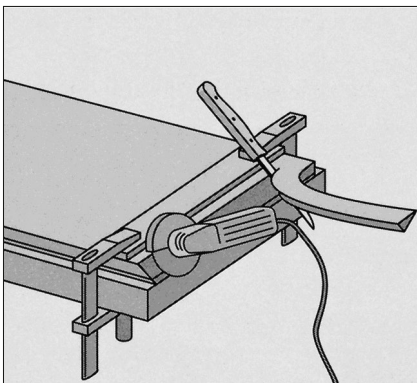

- > fasten the lagging to the work top by means of screw clamps
- > using a long blade knife in the overlapping width, bevel the rubber layer of the lagging from the adhesive layer flat up to the marked line (this might require two procedures)

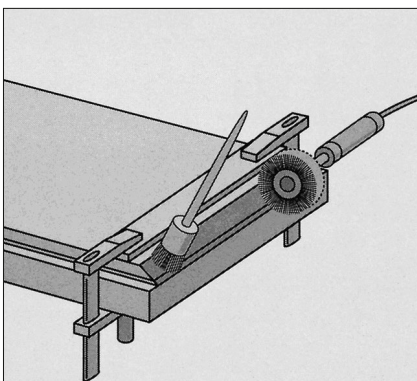

- > roughen the angular cut thoroughly by means of a grinding machine with a maximum rpm of 2000 or by means of a wire brush
- > lightly roughen an approximately 20 mm wide strip beyond the angular cut
- > any resultant dust must be removed by dry means
- > apply one coat of CONTI SECUR BFA to the roughened angular cut

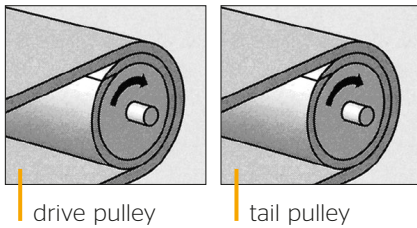

Lagging the Pulley

NB: In the case of pulley lagging with an overlap joint, the direction of overlap must be selected in such a way that the thrust forces so arising do not work against the joint. This prerequisite must be observed during the lagging process or when the lagged pulley is being installed.

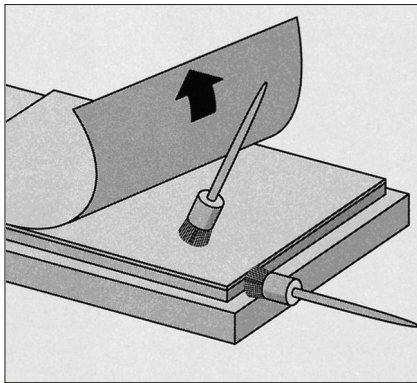

- › apply a second coat of CONTI SECUR BFA to the pre-prepared pulley cover
- › remove the strip of foil from the adhesive layer of the lagging
- › apply a thin coating of CONTI SECUR BFA to the adhesive layer only once
- › allow the coat on the pulley and the lagging to dry.
 - Drying time: back of the hand test, max. 10 minutes

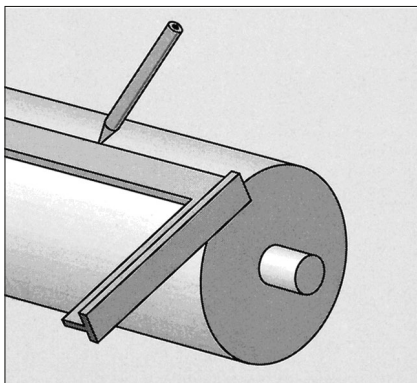

- › lay a try square on the side of the pulley
- › use a scribe to draw a lay-on line across the complete width of the pulley (do not use oil chalk)

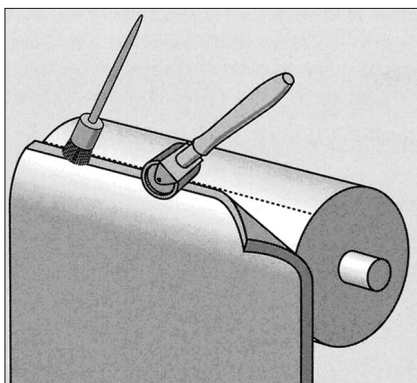

- › lay the cut edge of the lagging bevel along the marked line with the adhesive layer on the pulley cover, ensuring that the lagging projects over on both sides of the pulley corresponding to the width increment
- › roll the lagging bevel on to the pulley with a hand roller
- › apply a coat of CONTI SECUR BFA to the lagging bevel

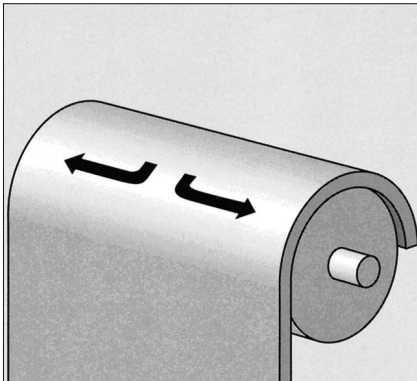

- › whilst continuing to turn the pulley slowly, press down the lagging by sweeping hand movements from the middle towards the edges. Any air bubbles trapped underneath should be pressed out.

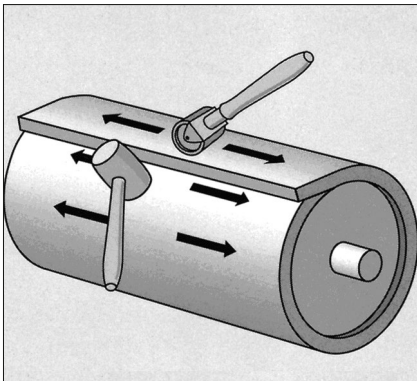

- › lay the lagging end on the lagging bevel
- › with a hand roller, roll the entire lagging firmly from the middle outwards
- › the overlap should be rolled with particularly firmness and hammered with a suitable mallet

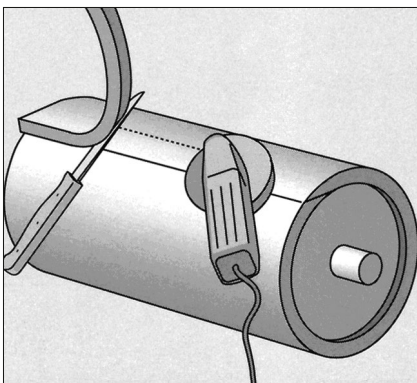

- › scarf the overlapping lagging end, matching it to the pulley contour as much as possible
- › carefully scour this cut surface clean by means of an angle grinding machine with a maximum rpm of 2000

Attention!

Grind **with** the run of the joint and **not against** the cement.

- › any resultant dust should be removed by dry means
- › if diamond lagging is to be used, then cut the surface grooves in the area of overlap with a groove trimmer

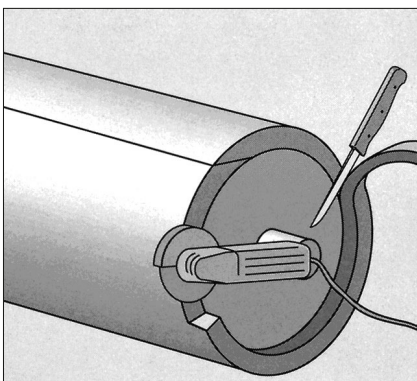

- › on the pulley edges, cut off the overlapping lagging by a bevel at an angle of approximately 30°
- › using an angle grinder with a maximum of 2000 rpm, grind this angular cut smooth
- › any resultant dust must be removed by dry

Lagging the Pulley - V-Joint

Attention!

Before the pulley is lagged, the steps described on Pages 8 and 9 must be carried out.

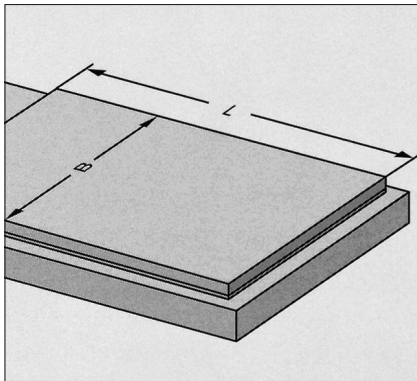

Preparing the Pulley Lagging

- › calculate the dimensions:
 - lagging width = pulley length + approx. 40 mm
 - lagging length = (pulley \varnothing + pulley thickness) x 3,14
- Example:** pulley \varnothing 500 mm
 lagging thickness 10 mm
 510 mm x 3,14 = 1601 mm
- › after calculating the dimensions, cut at right angles

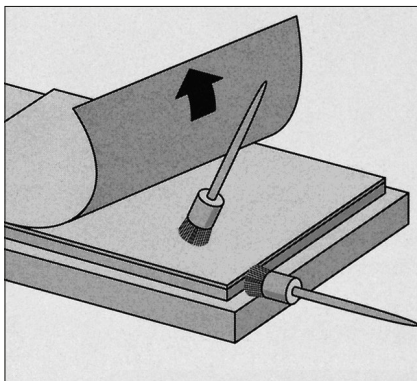

Lagging the Pulley

- › apply a second coat of CONTI SECUR BFA to the pre-prepared pulley cover
- › remove the protective foil from the adhesive layer of the lagging
- › apply CONTI SECUR BFA to the adhesive layer only once and thinly
- › allow the application on the pulley and the lagging to dry.
 - Drying time: back of the hand test, max. 10 minutes

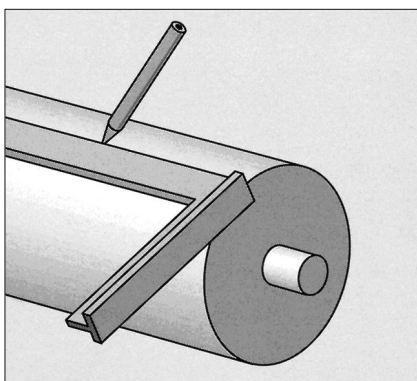

- › lay a try square on the side of the pulley
- › use a scribe to draw a lay-on line across the complete width of the pulley (do not use oil chalk)
- › place the pulley lagging on the marked line in such a way that the lagging overlaps uniformly on both pulley sides
- › roll the lagging on to the pulley firmly

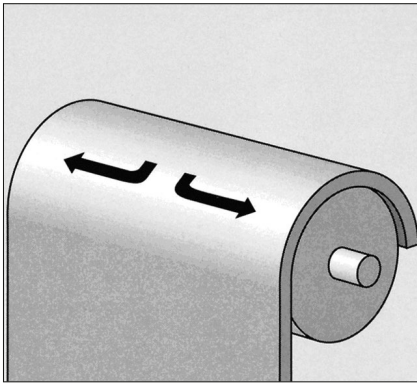

- › whilst continuing to turn the pulley slowly, press down the lagging by sweeping hand movements from the middle towards the edges. Any air bubbles trapped underneath should be pressed out.

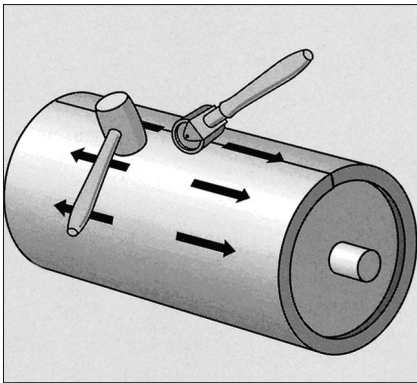

- › bring the lagging ends in front of one another
- › roll the lagging with a hand roller from the middle outwards
- › hammer flat with a suitable mallet

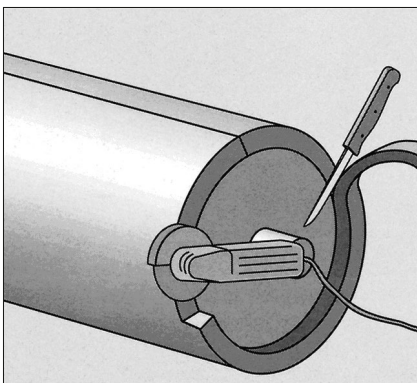

- › at the pulley edge, cut off the overlapping lagging by a bevel angle of approximately 30° to the middle of the pulley
- › using a grinder with a maximum of 2000 rpm, lightly scour this angular cut smooth

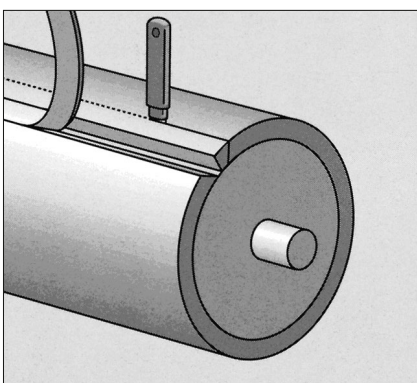

- › use a sharp knife to cut both lagging ends parallel to the joint at an approximately 30° angle up to the pulley surface, thus causing a lagging-free strip to form at the base of the V-incision. This should be as wide as the thickness of the selected pulley lagging.
- › pull out the cut strip

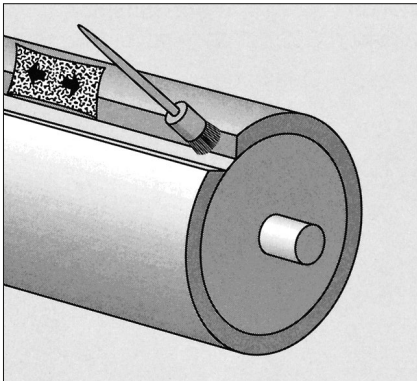

- > roughen the V-incision with sandpaper, or wire brush
- > any resultant dust should be removed by dry means
- > apply a coat of CONTI SECUR BFA to the V-incision
- > allow this first coat to dry for at least 30 minutes at room temperature

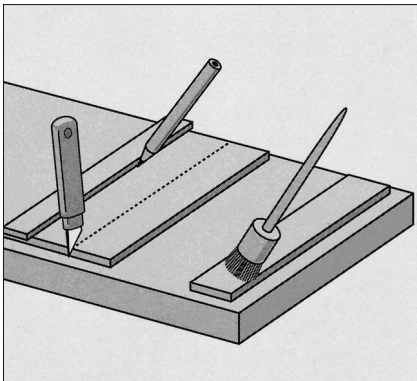

- > cut to shape a suitable strip out of CONREMA sheet rubber (1.5 or 3 mm thick) with double-sided adhesive layer
- > length: pulley width + 20 mm; width: approx. 3 times that of the lagging thickness
- > apply a second coat of CONTI SECUR BFA to the V-incision
- > simultaneously apply a thin coat of CONTI SECUR BFA to an adhesive layer side of the CONREMA filler rubber
- Drying time: back of the hand test, max. 10 minutes

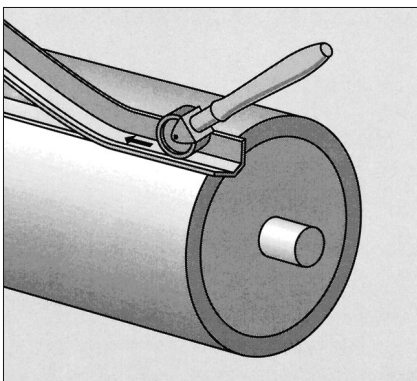

- > place the strip of filler rubber with the adhesive layer side facing downwards into the incision
- > roll firmly with a serration roller

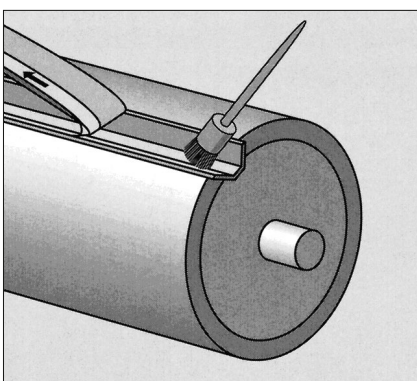

- > peel off the protective foil from the inserted strip

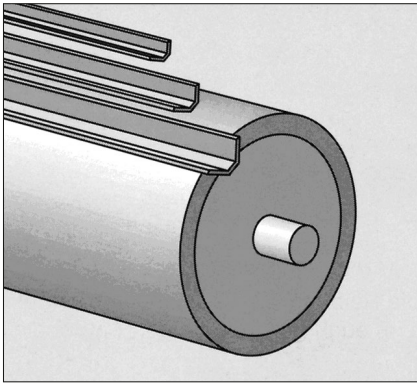

- › repeat those procedures in a logical sequence until the V-joint has been progressively filled in; cut to shape the top layer out of CONREMA repair sheet with one-sided adhesive layer
- › allow the filler material to increase the adhesion, which requires about 2 hours

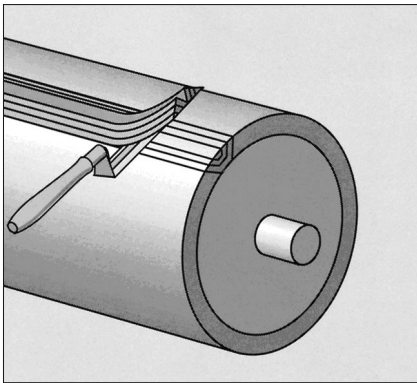

- › scarf the overlapping material to match the contour of the pulley

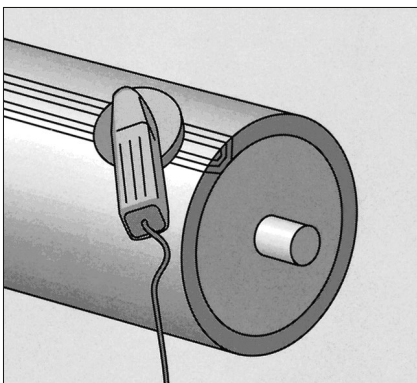

- › scour the top surface smooth, according to pulley contour, by means of an angle grinder with a maximum of 2000 rpm
- › in the case of diamond lagging, the grooves can be cut with a groove trimmer

Abrasion Protection with CORREX Lining Material

Processing this material is similar to the procedure for lagging pulleys.

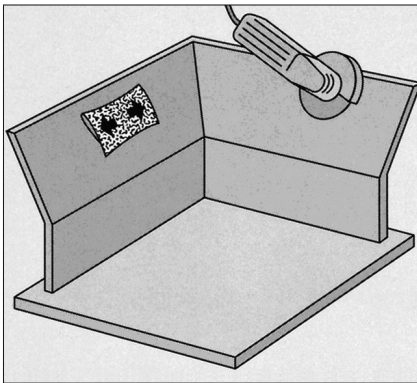

Preparing the Surfaces

- › the metal surfaces of the slides, chutes, pick-up or transfer hoppers and bunkers etc that are to be lagged with CORREX must be first thoroughly derusted and metallically cleaned by means of sandblasting or sandpapering
- › brush the resultant dust dry away carefully
- › wash the surfaces with solvent e.g. Conti Cleaning Solution

Attention!

Observe all safety-at-work regulations. Ensure that the rooms are properly ventilated. Do not work in closed-off bunkers or rooms.

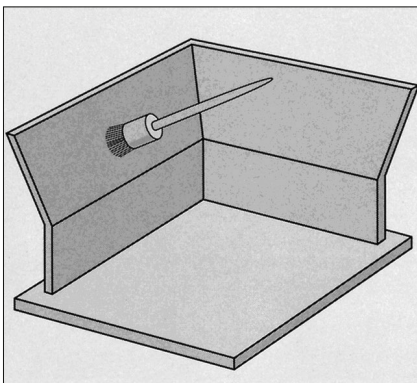

- › apply a thin coat of CONTI PLUS to the pre-prepared metal surface at a recommended rate of about 100 g/m²

Attention!

CONTI PLUS is not authorised for underground use.

- › allow the coating of CONTI PLUS to dry completely
 - drying time min. 30 mins (at temperature of 22 - 25 °C)
- › mix CONTI SECUR BFA with the activator solution and stir well; this mix can be used for 2 to 5 hours, depending of the ambient temperature
- › the following advice must be heeded when working with CONTI SECUR BFA:
 - slightly flammable - do not smoke
 - avoid breathing in the fumes
 - observe the MAC limits (maximum allowable concentration) of 300 ppm
 - use breathing masks fitted with A2 filter if the concentration is higher
- › apply the first coat of CONTI SECUR BFA with a bristle brush thinly
- › let the first coat dry thoroughly
 - drying time min. 30 mins (at temperature of 22 - 25 °C)

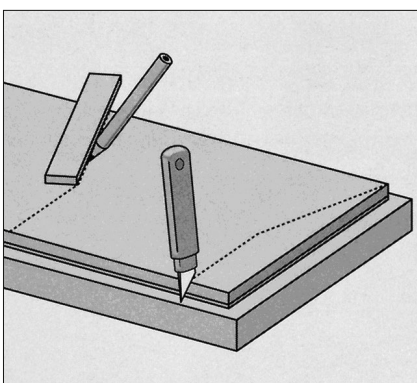

Preparing the CORREX sheeting

- › ascertain the precise dimensions of the areas to be lagged
- › in the event of asymmetrical, polygonal surfaces it might be worth making a stencil by positioning, marking and cutting paper or shirting fabric to the right shape
- › place the CORREX lagging with the adhesive layer facing downwards on to the work top
- › cut to shape the CORREX sheeting in accordance with the measurements taken or with the stencil made above

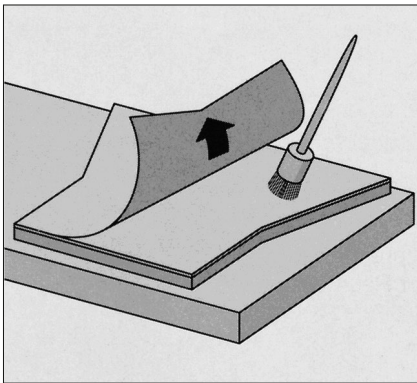

Lining the Surfaces

- › apply a second coat of CONTI SECUR BFA to the metal surface
- › peel the protective foil off the cut-to-shape sheet of CORREX
- › apply a thin coat of CONTI SECUR BFA to the adhesive layer once only
- › allow the coated bonding surfaces to dry.
 - Drying time: back of the hand test, max. 10 minutes

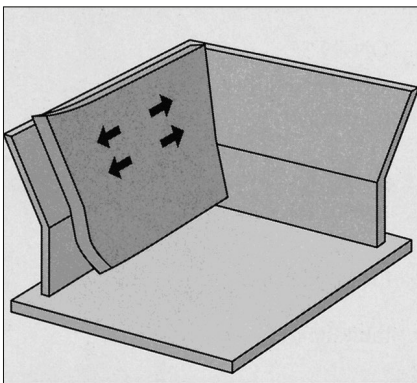

- › position the cut-to-shape sheet of CORREX at one edge of the surface to be covered and press firmly
- › hold the lagging in an arched form, dewind slowly and press it down by sweeping hand movements from the middle outwards

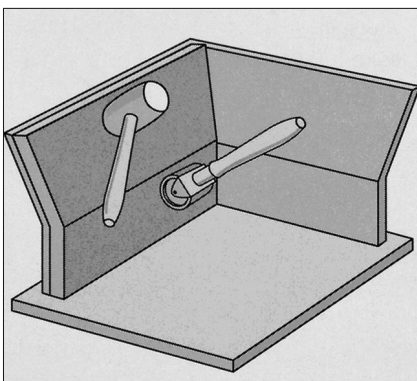

- › roll the entire surface area with a broad hand roller from the middle outwards. Any air bubbles trapped underneath should be pressed out.
- › hammer the lagging flat with a suitable mallet

NB: Before chutes or transfer stations are commissioned, the bonding should have had at least 12 hours to set.

ContiTech Deutschland GmbH

30173 Hannover, Germany
www.continental-industry.com

Please contact us:

[www.continental-industry.com/
contact-forms/general-contact-form](http://www.continental-industry.com/contact-forms/general-contact-form)



Legal notice

The content of this publication is not legally binding and is provided as information only. The trademarks displayed in this publication are the property of Continental AG and/or its affiliates. Copyright © 2024 ContiTech Deutschland GmbH, Hanover. All rights reserved. For complete information go to: www.continental-industry.com/discl_en