



Equipment Catalog

Shop In A Box, Crimpers, Smart Test Benches,
Hose Saws, Accessories, Dies, Ultra Clean Products
& Replacement Parts

Table of Contents

CONTINENTAL'S SHOP IN A BOX

- What's Included..... 5
- Shop In A Box Configurations..... 5
- PC125-RCD Shop In A Box..... 6
- PC160i Shop In A Box..... 8
- PC150HD Shop In A Box..... 10
- PC200i Shop In A Box..... 12
- PC200M Shop In A Box..... 14
- PC440i Shop In A Box..... 16
- Full Turnkey Solution..... 18
- Shop in A Box Weights & Dimensions..... 19

CRIMPERS

- PC100S-RCD Portable Series Crimper..... 22
- PC120M Portable Series Crimper..... 24
- PC125M-RCD Series Crimper..... 26
- PC125-RCD Series Crimper..... 28
- PC150HD Series Crimper..... 30
- PC150HDX Series Crimper..... 32
- PC200M Series Crimper..... 34

CRIMPERS WITH CRIMPIQ™ CONTROLLER

- PC160i Series with CrimpIQ™ Controller..... 38
- PC200i Series with CrimpIQ™ Controller..... 40
- PC440i Series with CrimpIQ™ Controller..... 42
- PC600i Series with CrimpIQ™ Controller..... 44
- PC1000i Series with CrimpIQ™ Controller..... 46
- PC1200i Series with CrimpIQ™ Controller..... 48

CRIMPER QUICK INFO CHART..... 50

SMART TEST BENCH CONTROLLER

- Smart Test Bench Controller Series..... 54

CRIMPIQ™ CONTROLLER RETRO-FIT KIT

- PC200 and PC400 Series Retro-Fit Kit..... 56

CRIMPCLOUD® MANAGEMENT & TRACEABILITY

- CrimpCloud® Management & Traceability..... 58
- Everything You Need To Know..... 60
- Choose From Two Tiers Of Access..... 61
- CrimpCloud® Accessories..... 62
- Technical Specifications ZT231 Industrial Printer..... 63

HOSE SAWS

- HS-150 Series..... 66
- HS-500 Series..... 68

HOSE REEL RACKS..... 70

FITTING PUSHERS

- CC-FP10 Series Fitting Pusher..... 72

CRIMPER SPARE PART KITS

- PC125RCD..... 74
- PC125..... 74
- PC150/PC160i..... 74
- PC150H..... 74
- PC150HD..... 74
- PC200..... 74
- PC400..... 74



Scan here to learn more about your machines!

Table of Contents

CALIPERS

Bluetooth and Notched Calipers..... 75

DIE SERIES

PC125..... 76
 PC125RCD 76
 PC120M..... 77
 PC160i 78
 PC160i WB..... 78
 PC150 Double Angle..... 79
 PC150H..... 80
 PC200 80
 PC600i..... 81
 PC1000i 81
 PC1200i 82
 PC125-AC..... 83
 PC125RCD-AC 83
 PC150-AC..... 83
 PC150H-AC..... 83
 PC200-AC 83

DIE SERIES DECALS

PC150H and PC200 Die Decals Replacement Kit 84
 PC150H and PC200 Die Series individual Decals 84

REPLACEMENT PARTS

Insertion Blocks 85
 CrimpIQ™ Controller and Accessories..... 85
 Removable Pushers & Pusher Retaining Pins 85
 Pressure Plates 86

T420 Pressure Plates..... 86
 Spacer Kits 86
 Compression Rings..... 87
 Die Storage Shelves and Racks 87
 Die Lubricant 88
 Die Removal Tools 88
 Foot Switches 89
 Adjustable Coupling Stops and
 Manual/Electric Back Stops..... 89
 Micrometers..... 90
 Protective Master Die Foam Pads..... 90
 Die Springs and Screws 91
 Die Lock Studs..... 91
 Master Die Lock Studs..... 91
 Hose Saw Blades and Accessories 92
 Hand, Pneumatic and Electric Pumps..... 92

ULTRA CLEAN PRODUCTS 93

ELECTRICAL PLUG CONFIGURATIONS 95

PREVENTATIVE MAINTENANCE PACKAGES

PC200, PC400, PC440, PC600,
 PC600L and PC1000 Series Crimpers..... 96

CRIMPER CALIBRATION SERVICES 97

CLASSIC CRIMPERS

PC125M Series..... 98
 PC125 Series 98

Continental

SHOP IN A BOX SOLUTIONS MADE EASY



GENERATE MORE REVENUE WITH CONTINENTAL'S SHOP IN A BOX

Now you can create a hydraulic and industrial hose crimp shop right inside your current location with Continental's Shop In A Box. This turnkey set up contains a crimper and all the accessories you need to produce premium Continental assemblies.



- 1 CrimplQ™ Tablet not included w/ smart equipment.
- 2 Ultra Clean Starter Kit only included w/ PC160i SIAB.
- 3 The SIAB has an improvement in packaging, has now evolved into industrial strength cardboard for easier and lighter unboxing.

SHOP IN A BOX CONFIGURATIONS

PC125-RCD



PC160i



PC150HD



PC200M



PC200i



PC440i



PC125-RCD SHOP IN A BOX

Now you can create a hydraulic hose crimp shop right inside your current location with PC125-RCD Shop in a Box. This turnkey setup is a new assembly solution containing a hose saw, crimper and all the accessories you need to produce premium Continental assemblies.

FEATURES

FULL TURNKEY SOLUTION

- › Everything you need right inside your current location
- › To produce premium Continental hydraulic hose assemblies

CAPABILITY

- › The PC125-RCD is designed to crimp (-20) B2 Fittings and (-16) SG Fittings
- › The HS-150 is designed to cut 1- and 2-braid hydraulic hose up to 1 ½" ID and up to 1 ¼" 4-spiral hose



HYDRAULIC EQUIPMENT



Shop in a Box
PC125-RCD

PC125-RCD SHOP IN A BOX



PC125-RCD Shop in a Box Standard Package Includes:				
Description	Qty	Description	Qty	
1 24" Hose Reel Rack (Hose spools not included)	1	8 CrimpIQ™ Tablet and Mounting Arm	1	
2 6' LED Light Kit	1	9 Tape Measure	1	
3 6' Continental Sign	1	10 PC125-RCD Tooling Box, and Tooling Mat	1	
4 Hose Helper prevents the hose from being drawn back during a cut and gives the operator the ability to more precisely control the cut length	1	11 PC125-RCD Crimper (Dies, Drawer, and Tooling Box)	1	
5 10' Continental Air Hose with Nozzle	1	12 5' 110V Power Strip	1	
6 HS-150 Hose Saw (Handle, Vacuum Port, and Alignment Pins)	1	13 4 Drawer Cabinet with Small and Large Bins	1	
7 Insertion Block Assembly (B2 and SG blocks, 2 Paint Markers)	1	14 Adjustable Feet	4	

SAP #	PC125-RCD SHOP IN A BOX							
	Voltage	Phase	Plug	Hertz	Country Approved	Dies Included	Die Sizes (mm)	Hose Saw
21091383	110V	1	NEMA 5-15	60	*CAN, MEX, USA	8	16, 19, 23, 27, 31, 34, 43, 50	HS-150

*CSA rated components are being used, but CSA decal is only applied to crimper.

Shop in a Box
PC125-RCD

HYDRAULIC EQUIPMENT



PC160i SHOP IN A BOX

Now you can create a hydraulic hose crimp shop right inside your current location with PC160i Shop in a Box. This turnkey setup is a new assembly solution containing a hose saw, crimper and all the accessories you need to produce premium Continental assemblies.

FEATURES

FULL TURNKEY SOLUTION

- › Everything you need right inside your current location
- › To produce premium Continental hydraulic hose assemblies

CAPABILITY

- › The PC160i is designed to crimp -20 SG Fittings and up to -32 B2 Fittings (only w/ wide body dies)
- › The HS-501 is designed to cut 1- and 2-braid hydraulic hose up to 2" ID and up to 2" 4- or 6-spiral hose



HYDRAULIC EQUIPMENT



Shop in a Box
PC160i

PC160i SHOP IN A BOX

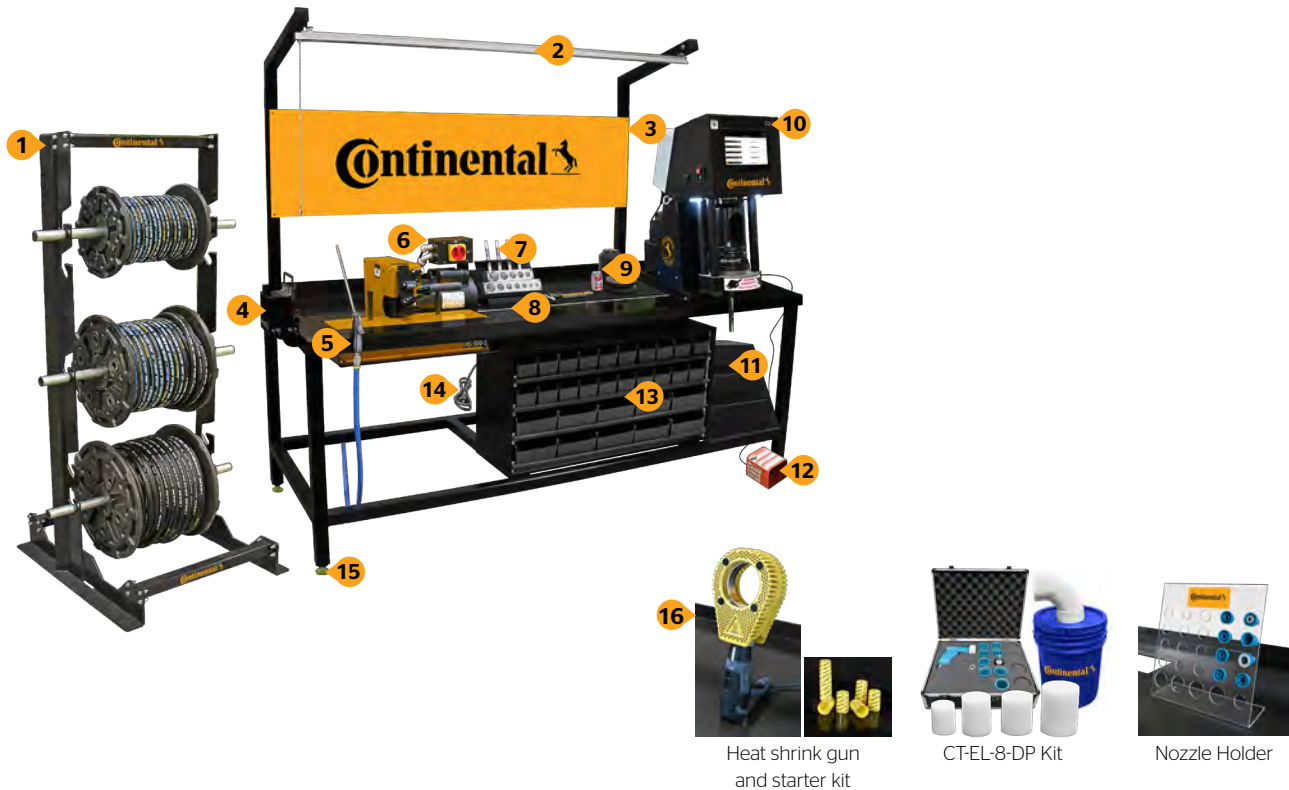

PC160i Shop in a Box Standard Package Includes:			
Description	Qty	Description	Qty
1 36" Hose Reel Rack (Hose spools not included)	1	9 PC160i Tooling Box, and Tooling Mat	1
2 6' LED Light Kit	1	10 PC160i Crimper (Dies, Shelf and Tooling Box)	1
3 6' Continental Sign	1	11 Die Shelf	1
4 Hose Helper prevents the hose from being drawn back during a cut and gives the operator the ability to more precisely control the cut length	1	12 Foot Pedal	1
5 10' Continental Air Hose with Nozzle	1	13 4 Drawer Cabinet with Small and Large Bins	1
6 HS-501 Hose Saw (Handle, Vacuum Port, and Alignment Pins)	1	14 5' 110V Power Strip	1
7 Insertion Block Assembly (B2 and SG blocks, 2 Paint Markers)	1	15 Adjustable Feet	4
8 Tape Measure	1	16 Ultra Clean Starter Kit	1

SAP #	PC160i SHOP IN A BOX							
	Voltage	Phase	Plug	Hertz	Country Approved	Dies Included	Die Sizes (mm)	Hose Saw
21189470	220V	1	NEMA 6-20	60	*CAN, MEX, USA	10	16, 19, 23, 27, 31, 34, 41, 45, 56, 53WB	HS-501

*CSA rated components are being used, but CSA decal is only applied to crimper.

Shop in a Box
PC160i

HYDRAULIC EQUIPMENT



PC150HD SHOP IN A BOX

Now you can create a hydraulic hose crimp shop right inside your current location with PC150HD Shop in a Box. This turnkey setup is a new assembly solution containing a hose saw, crimper and all the accessories you need to produce premium Continental assemblies.

FEATURES

FULL TURNKEY SOLUTION

- › Everything you need right inside your current location
- › To produce premium Continental hydraulic hose assemblies

CAPABILITY

- › PC150HD is designed to crimp 1/4" - 2" ID, 2-braid hose and 1 1/4" 6-spiral hose with all coupling end styles and most bent tubes.
- › The HS-501 is designed to cut 1- and 2-braid hydraulic hose up to 2" ID and up to 2" 4- or 6-spiral hose



HYDRAULIC EQUIPMENT



Shop in a Box
PC150HD

PC150HD SHOP IN A BOX

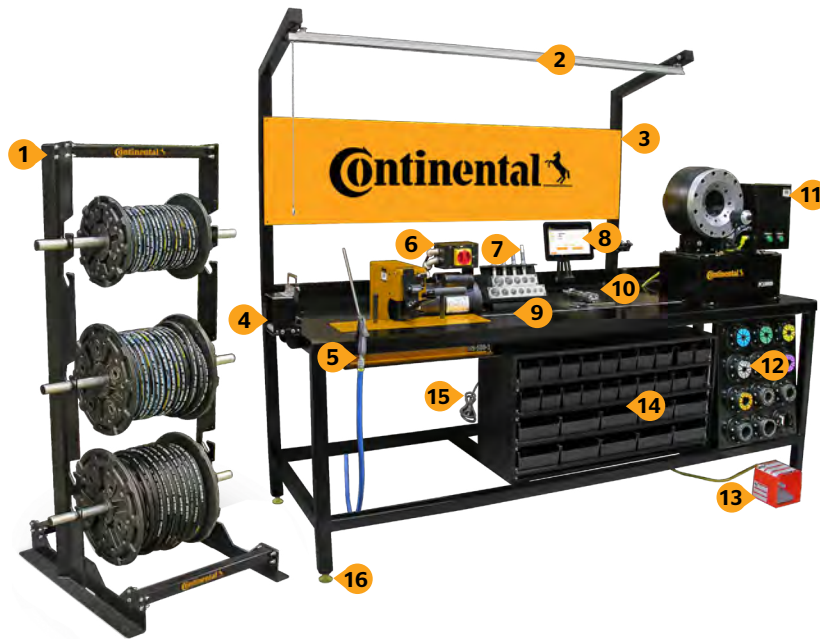

PC150HD Shop in a Box Standard Package Includes:			
Description	Qty	Description	Qty
1 36" Hose Reel Rack (Hose spools not included)	1	9 Tape Measure	1
2 6' LED Light Kit	1	10 PC150HD Tooling Box, and Tooling Mat	1
3 6' Continental Sign	1	11 PC150HD Crimper (Dies, Rack, and Tooling Box)	1
4 Hose Helper prevents the hose from being drawn back during a cut and gives the operator the ability to more precisely control the cut length	1	12 Die Rack	1
5 10' Continental Air Hose with Nozzle	1	13 Foot Pedal	1
6 HS-501 Hose Saw (Handle, Vacuum Port, and Alignment Pins)	1	14 4 Drawer Cabinet with Small and Large Bins	1
7 Insertion Block Assembly (B2 and SG blocks, 2 Paint Markers)	1	15 5' 110V Power Strip	1
8 CrimpIQ™ Tablet and Mounting Arm	1	16 Adjustable Feet	4

SAP #	PC150HD SHOP IN A BOX							
	Voltage	Phase	Plug	Hertz	Country Approved	Dies Included	Die Sizes (mm)	Hose Saw
21100773	220V	1	NEMA 6-20	60	*CAN, MEX, USA	12	16, 19, 23, 27, 31, 34, 41, 45, 50, 53, 56, 69	HS-501

*CSA rated components are being used, but CSA decal is only applied to crimper.

Shop in a Box
PC150HD

HYDRAULIC EQUIPMENT



PC200i SHOP IN A BOX

Now you can create a hydraulic hose crimp shop right inside your current location with PC200i Shop in a Box. This turnkey setup is a new assembly solution containing a hose saw, crimper and all the accessories you need to produce premium Continental assemblies.

FEATURES

FULL TURNKEY SOLUTION

- › Everything you need right inside your current location
- › To produce premium Continental hydraulic hose assemblies

CAPABILITY

- › PC200i is designed to crimp 1/4" - 2" ID, 2-braid hose and 2" 6 spiral hose with all coupling end styles and most bent tubes.
- › The HS-501 is designed to cut 1- and 2-braid hydraulic hose up to 2" ID and up to 2" 4- or 6-spiral hose



HYDRAULIC EQUIPMENT



Shop in a Box
PC200i

PC200i SHOP IN A BOX

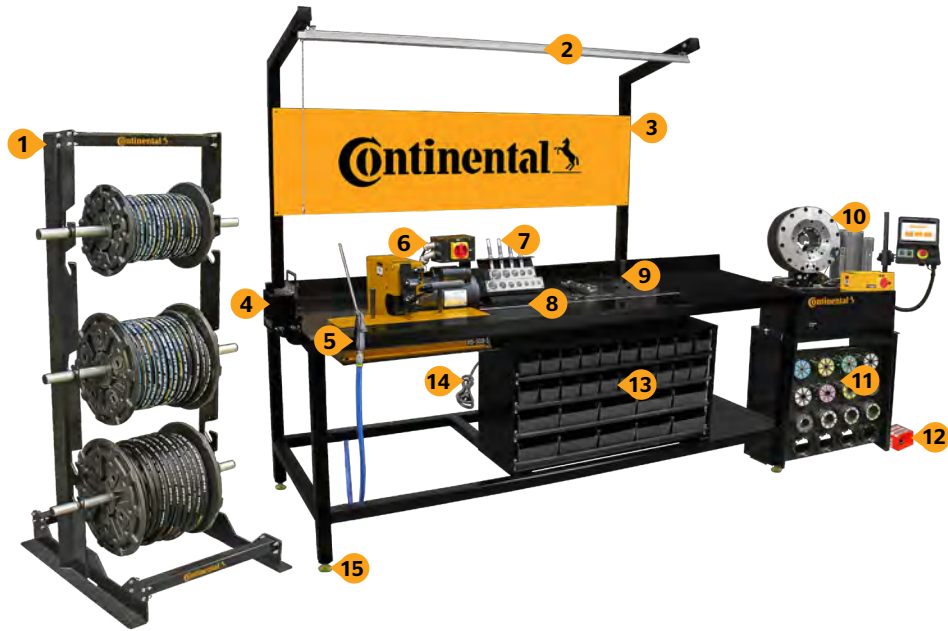

PC200i Shop in a Box Standard Package Includes:				
Description		Qty	Description	
1	36" Hose Reel Rack (Hose spools not included)	1	9	PC200i Tooling Box, and Tooling Mat
2	6' LED Light Kit	1	10	PC200i Crimper (Dies, PC200 Rack, and Tooling Box)
3	6' Continental Sign	1	11	PC200-Rack
4	Hose Helper prevents the hose from being drawn back during a cut and gives the operator the ability to more precisely control the cut length	1	12	Foot Pedal
5	10' Continental Air Hose with Nozzle	1	13	4 Drawer Cabinet with Small and Large Bins
6	HS-501 Hose Saw (Handle, Vacuum Port, and Alignment Pins)	1	14	5' 110V Power Strip
7	Insertion Block Assembly (B2 and SG blocks, 2 Paint Markers)	1	15	Adjustable Feet
8	Tape Measure	1		

SAP #	PC200i SHOP IN A BOX							
	Voltage	Phase	Plug	Hertz	Country Approved	Dies Included	Die Sizes (mm)	Hose Saw
21100775	230V	1	NEMA L6-30P	60	*CAN, MEX, USA	14	16, 19, 23, 27, 31, 34, 41, 45, 50, 53, 59, 62, 74, 78	HS-501
21100777	230V	3	NEMA L15-20P	60	*CAN, MEX, USA	14	16, 19, 23, 27, 31, 34, 41, 45, 50, 53, 59, 62, 74, 78	HS-500
21100518	440-480V	3	NEMA L16-20P	60	*CAN, MEX, USA	14	16, 19, 23, 27, 31, 34, 41, 45, 50, 53, 59, 62, 74, 78	HS-500-480V

*CSA rated components are being used, but CSA decal is only applied to crimper.

Shop in a Box
PC200i

HYDRAULIC EQUIPMENT



PC200M SHOP IN A BOX

Now you can create a hydraulic hose crimp shop right inside your current location with PC200M Shop in a Box. This turnkey setup is a new assembly solution containing a hose saw, crimper and all the accessories you need to produce premium Continental assemblies.

FEATURES

FULL TURNKEY SOLUTION

- › Everything you need right inside your current location
- › To produce premium Continental hydraulic hose assemblies

CAPABILITY

- › PC200M is designed to crimp 1/4" - 2" ID, 2-braid hose and 2" 6 spiral hose with all coupling end styles and most bent tubes.
- › The HS-501 is designed to cut 1- and 2-braid hydraulic hose up to 2" ID and up to 2" 4- or 6-spiral hose



HYDRAULIC EQUIPMENT



Shop in a Box
PC200M

PC200M SHOP IN A BOX

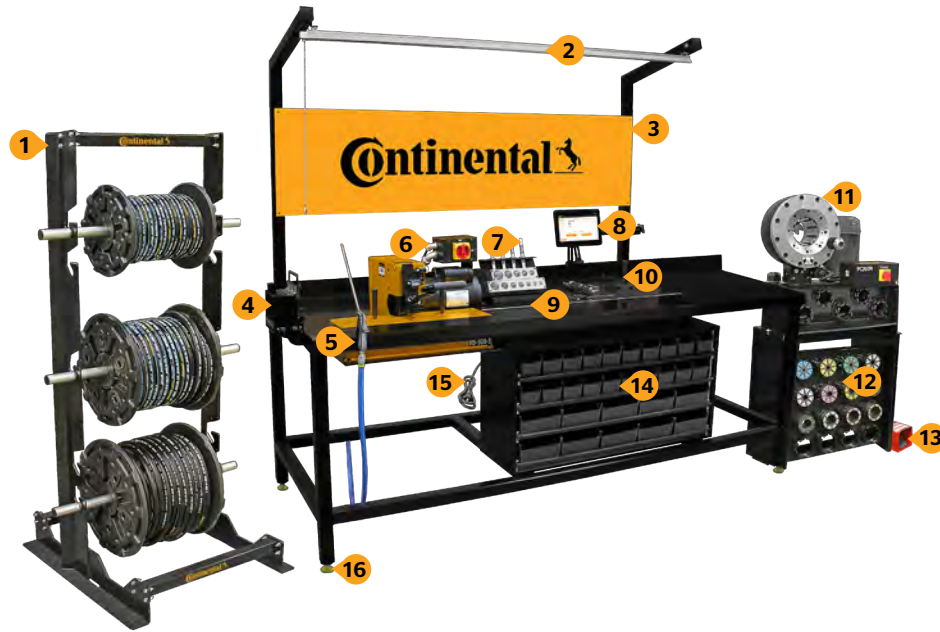

PC200M Shop in a Box Standard Package Includes:			
Description	Qty	Description	Qty
1 36" Hose Reel Rack (Hose spools not included)	1	9 Tape Measure	1
2 6' LED Light Kit	1	10 PC200M Tooling Box, and Tooling Mat	1
3 6' Continental Sign	1	11 PC200M Crimper (Dies, PC200 Rack, and Tooling Box)	1
4 Hose Helper prevents the hose from being drawn back during a cut and gives the operator the ability to more precisely control the cut length	1	12 PC200-Rack	1
5 10' Continental Air Hose with Nozzle	1	13 Foot Pedal	1
6 HS-501 Hose Saw (Handle, Vacuum Port, and Alignment Pins)	1	14 4 Drawer Cabinet with Small and Large Bins	1
7 Insertion Block Assembly (B2 and SG blocks, 2 Paint Markers)	1	15 5' 110V Power Strip	1
8 CrimpIQ™ Tablet and Mounting Arm	1	16 Adjustable Feet	4

PC200M SHOP IN A BOX								
SAP #	Voltage	Phase	Plug	Hertz	Country Approved	Dies Included	Die Sizes (mm)	Hose Saw
21127394	230V	1	NEMA L6-30P	60	*CAN, MEX, USA	14	16, 19, 23, 27, 31, 34, 41, 45, 50, 53, 59, 62, 74, 78	HS-501

*CSA rated components are being used, but CSA decal is only applied to crimper.

Shop in a Box
PC200M

HYDRAULIC EQUIPMENT



PC440i SHOP IN A BOX

Now you can create a hydraulic hose crimp shop right inside your current location with PC440i Shop in a Box. This turnkey setup is a new assembly solution containing a hose saw, crimper and all the accessories you need to produce premium Continental assemblies.

FEATURES

FULL TURNKEY SOLUTION

- › Everything you need right inside your current location
- › To produce premium Continental hydraulic & industrial hose assemblies

CAPABILITY

- › PC440i is designed to crimp 1/4" - 2" ID, 2-braid hose, 2" 6 spiral hose and 4" industrial hose with all coupling end styles and most bent tubes.
- › The HS-500 is designed to cut 1- and 2-braid hydraulic hose up to 2" ID and up to 2" 4- or 6-spiral hose



HYDRAULIC EQUIPMENT



Shop in a Box

PC440i

PC440i SHOP IN A BOX

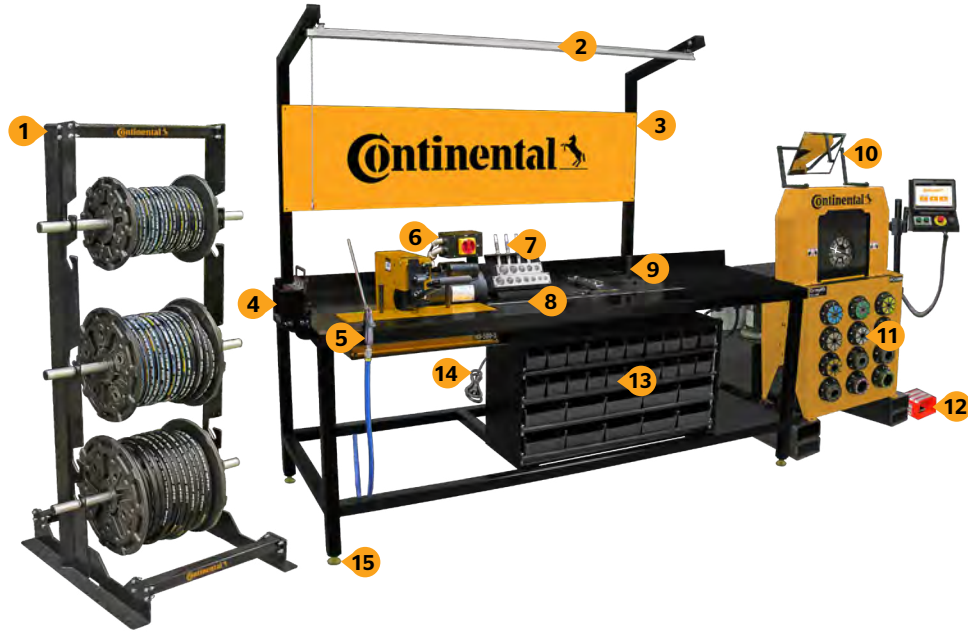

PC440i Shop in a Box Standard Package Includes:			
Description	Qty	Description	Qty
1 36" Hose Reel Racks (Hose spools not included)	1	9 PC440i Tooling Box, and Tooling Mat	1
2 6' LED Light Kit	1	10 PC440i Crimper (Dies, Built-In Die Storage, and Tooling Box)	1
3 6' Continental Sign	1	11 Built-In Die Storage	1
4 Hose Helper prevents the hose from being drawn back during a cut and gives the operator the ability to more precisely control the cut length	1	12 Foot Pedal	1
5 10' Continental Air Hose with Nozzle	1	13 4 Drawer Cabinet with Small and Large Bins	1
6 HS-501 Hose Saw (Handle, Vacuum Port, and Alignment Pins)	1	14 5' 110V Power Strip	1
7 Insertion Block Assembly (B2 and SG blocks, 2 Paint Markers)	1	15 Adjustable Feet	4
8 Tape Measure	1		

PC440i SHOP IN A BOX								
SAP #	Voltage	Phase	Plug	Hertz	Country Approved	Dies Included	Die Sizes (mm)	Hose Saw
21139797	230V	3	NEMA L15-20P	60	*CAN, MEX, USA	14	16, 19, 23, 27, 31, 34, 41, 45, 50, 53, 59, 62, 74, 78	HS-500

*CSA rated components are being used, but CSA decal is only applied to crimper.

Shop in a Box
PC440i

HYDRAULIC EQUIPMENT



SHOP IN A BOX Full Turnkey Solution

SHOP IN A BOX Full Turnkey Solution

FULL TURNKEY SOLUTION

- › Remove cardboard box
- › Lift table off pallet
- › Position in place
- › Assemble 6' LED light kit¹
- › Assemble hose reel rack²
- › Plug in equipment
- › Cut and crimp hose



1 The 6' LED light kit needs to be assemble - see LED light installation instructions for more details.

2 The hose reel rack needs to be assemble - see quick start guide/hose reel rack assembly instructions for more details.

SHOP IN A BOX Weights & Dimensions



SHOP IN A BOX Weights & Dimensions		
SIAB Model	Weight	Dimensions
PC125-RCD SHOP IN A BOX	1,385 lbs.	108" L x 48" W x 78" H
PC160i SHOP IN A BOX	1,780 lbs.	108" L x 48" W x 78" H
PC150HD SHOP IN A BOX	1,650 lbs.	108" L x 48" W x 78" H
*PC200i SHOP IN A BOX	1,160 lbs	108" L x 48" W x 78" H
PC200i Crimper	1,040 lbs	48" L x 40" W x 62" H
*PC200M SHOP IN A BOX	1,160 lbs	108" L x 48" W x 78" H
PC200M Crimper	1,000 lbs	48" L x 40" W x 62" H
*PC440i SHOP IN A BOX	1,160 lbs.	108" L x 48" W x 78" H
PC440i Crimper	2,915 lbs.	54" L x 44" W x 61" H

*PC200i/PC200M/PC440i Shop in a box, the crimper comes in a separate skit.

Shop in a Box
Weights & Dimensions

HYDRAULIC EQUIPMENT



Ergonomic

Reliable

Portable



Economical



profit

Continental has the right equipment for all your hose assemblies.



- › Entry Level
- › Mobile Application
- › General Use



PC100S-RCD Portable Series Crimper

The PC100S-RCD crimper can be carried to the jobsite with a handle and support stand, making this crimper ideal for portable crimping requirements. Whether carried on-site, used in a vehicle or even stationary at the shop, the PC100S-RCD is designed as a low volume crimper for occasional use. The crimp diameter is set and controlled with an easy-to-read T420 micrometer. This affordable crimper is packaged in component parts to fit the needs of the user.

The PC100S-RCD standard package includes: T420 micrometer, LED light indicator, removable pusher, standard pressure plate, Continental digital caliper, die removal magnet, and CRIMPX die lubricant oil w/ dauber cap.

FEATURES

NOTCHED PRESSURE PLATE

- › Only when crimping 90° fittings



Lightweight portable crimper can be carried to almost any location where service is required.



Micrometer is fully adjustable for a precise crimp.



Easy lubrication maintenance.



Crimper position can be adjusted for optimum crimping position.

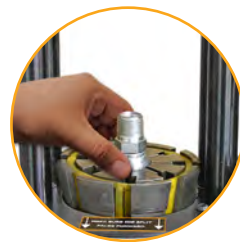

Open design allows the operator to accurately position the fitting prior to crimping.



LED indicator light will turn on to indicate that the crimp is complete.

PC100S-RCD Portable Series Crimper

CAPABILITY

- > (-16) B2 Fittings
- > (-08) SG Fittings

TECHNICAL DATA

CRIMPING FORCE 35 ton

WEIGHT 48 lbs. (crimper only)

DIMENSIONS 12 ½" L x 12 ½" W x 21 ½" H

DIE SERIES PC125RCD



AVAILABLE CONFIGURATIONS

SAP #	Pump	PSI	Reservoir Capacity	Country Approved	Dies Included	Die Sizes (mm)	Quick Disconnect Included	Drawer/Stand Included
21063190	Pneumatic	10,000	100 in ³ (1,639 cc)	CAN, MEX, USA	7	12, 16, 19, 23, 27, 31, 43	✓	✓
21063169	Hand	N/A	25 in ³ (1,410 cc)	CAN, MEX, USA	7	12, 16, 19, 23, 27, 31, 43	✓	✓

Crimpers

PC100S-RCD Portable Series

HYDRAULIC EQUIPMENT



PC120M Portable Series Crimper

The PC120M crimper can be transported easily to the jobsite, making this crimper ideal for portable crimping requirements. Whether transported on-site, used in a vehicle or even stationary at the shop, the PC120M is designed with ergonomics and good capability in mind. The crimp diameter is set and controlled with an easy-to-read metric micrometer. This affordable crimper is packaged in component parts to fit the needs of the user.

The PC120M standard package includes: Metric micrometer, LED light indicator, die carrying case, (6) die sets, 6 foot hose assembly, mini grease gun with CRIMPX die lubricant grease and Continental digital caliper.

FEATURES

COMPACT ENGINEERED DESIGN

- › Ideal for small workshops
- › Weighing only 58 lbs and mounted on a convenient carrying frame
- › The unit can be easily transported in vehicles for on-site jobs



Micrometer style adjustment is fully adjustable for a precise crimp.



Magnetic die mechanism.



Colored die size decals for easy identification.



LED indicator light will turn on to indicate that the crimp is complete.



6 foot hose assembly included.



Die carrying case included.

PC120M Portable Series Crimper

CAPABILITY

- > 1" Braided
- > 3/4" Spiral

TECHNICAL DATA

CRIMPING FORCE 120 ton

WEIGHT 58 lbs. (Crimper only)

DIMENSIONS 8.5" L x 10" W x 12" H

DIE SERIES PC120M





AVAILABLE CONFIGURATIONS

SAP #	Pump	PSI	Reservoir Capacity	Country Approved	Dies Included	Die Sizes (mm)	6 ft Hose Assembly Included	Die Carrying Case Included
21151022	*None	N/A	N/A	CAN, MEX, USA	6	16, 19, 23, 27, 31, 37	✓	✓

*Do not forget to buy your pump that best fits your portable crimping requirements. See the chart below.

OPTIONAL PUMP OPTIONS (PUMP ONLY)

SAP #	Pump	PSI	Reservoir Capacity	Country Approved	Pump Model
20244931	Hand	10,000	43 in. ³ (705 cc)	CAN, MEX, USA	
20244932	Pneumatic	10,000	100 in. ³ (1,639 cc)	CAN, MEX, USA	
20244916	110V - 3/4 HP	10,000	1 gallon	*CAN, MEX, USA	

*CSA rated components are being used, but CSA decal isn't applied.

Crimpers

PC120M Portable Series

HYDRAULIC EQUIPMENT



PC125M-RCD Portable Series Crimper

The PC125M-RCD crimper can be carried to the jobsite with a handle and support stand, and is ideal for portable crimping requirements. Whether carried on-site, used in a vehicle or even stationary at the shop, the PC125M-RCD is designed as a low volume crimper for occasional use. The crimp diameter is set and controlled with an easy-to-read T420 micrometer. This affordable crimper is packaged in component parts to fit the needs of the user.

The PC125M-RCD standard package includes: T420 micrometer, adjustable retraction stop, LED indicator light, removable pusher, standard pressure plate, notched pressure plate, Continental digital caliper, die removal magnet, and CRIMPX die lubricant oil w/ dauber cap.

FEATURES

ADJUSTABLE RETRACTION STOP

- › Limits ram retraction to only the amount required to remove the hose and coupling
- › Saves time on multiple, repetitive crimps



Portable rugged steel frame and strain rods provide strength, stability, and performance for all crimping service.



Micrometer style adjustment is fully adjustable for a precise crimp.



Easy lubrication maintenance.



Notched pressure plate ideal when crimping 90° fittings.



Open design allows the operator to accurately position the fitting prior to crimping.



LED indicator light will turn on to indicate that the crimp is complete.

PC125M-RCD Portable Series Crimper

CAPABILITY

- › (-20) B2 Fittings
- › (-16) SG Fittings

TECHNICAL DATA

CRIMPING FORCE 60 ton

WEIGHT 85 lbs. (Crimper only)

DIMENSIONS 17" L x 10 ¼" W x 18 ½" H

DIE SERIES PC125RCD





AVAILABLE CONFIGURATIONS

SAP #	Pump	PSI	Reservoir Capacity	Country Approved	Dies Included	Die Sizes (mm)	Quick Disconnect Included	Drawer/Stand Included
20821205	*None	N/A	N/A	CAN, MEX, USA	8	16, 19, 23, 27, 31, 34, 43, 50	✓	✓
20821204	*None	N/A	N/A	CAN, MEX, USA	None		✓	

*Do not forget to buy your pump that best fits your portable crimping requirements. See the chart below.

OPTIONAL PUMP OPTIONS (PUMP ONLY)

SAP #	Pump	PSI	Reservoir Capacity	Country Approved	Pump Model
20244931	Hand	10,000	43 in. ³ (705 cc)	CAN, MEX, USA	
20244932	Pneumatic	10,000	100 in. ³ (1,639 cc)	CAN, MEX, USA	
20244916	110V - 3/4 HP	10,000	1 gallon	*CAN, MEX, USA	

*CSA rated components are being used, but CSA decal isn't applied.

Crimpers

PC125M-RCD Portable Series

HYDRAULIC EQUIPMENT



PC125-RCD Series Crimper

The PC125-RCD crimper with its open design, removable pusher and easy-to-use, rubber-cage die set, is designed for higher production volume and repetitive use. Crimp diameter is set and controlled with an easy-to-read T420 micrometer. The PC125-RCD is packaged for shop service.

The PC125-RCD standard package includes: T420 micrometer, electronic stop switch, adjustable retraction stop, removable pusher, standard pressure plate, notched pressure plate, adjustable coupling stop, pneumatic start/stop pendant switch, Continental digital caliper, die removal magnet, and CRIMPX die lubricant oil w/ dauber cap.

FEATURES

PC125 STAND/DRAWER

- › The PC125-RCD crimper can be mounted on the PC125 Stand/Drawer
- › PC125RCD dies and crimping tooling can be stored in the drawer



Micrometer style adjustment is fully adjustable for a precise crimp.



Easy lubrication maintenance.



Notched pressure plate ideal when crimping 90° fittings.



Retraction stop limits ram retraction for quick repetitive crimps.



Coupling stop makes repetitive crimps faster.



Electronic stop switch shuts the pump off when the crimp cycle is complete.

PC125-RCD Series Crimper

CAPABILITY

- > (-20) B2 Fittings
- > (-16) SG Fittings

TECHNICAL DATA

CRIMPING FORCE 60 ton

WEIGHT 154 lbs. (crimper only)

DIMENSIONS 22 ½" L x 13" W x 22 ½" H

DIE SERIES PC125RCD

OIL CAPACITY 1 gallon



AVAILABLE CONFIGURATIONS

SAP #	Voltage	Phase	Plug	Hertz	Country Approved	Dies Included	Die Sizes (mm)	Drawer/Stand Included
20809573	110V	1	NEMA 5-15	60	CAN, MEX, USA	8	16, 19, 23, 27, 31, 34, 43, 50	✓
20969061	220V	1	NEMA 6-20	60	CAN, MEX, USA	8	16, 19, 23, 27, 31, 34, 43, 50	✓
20809571	110V	1	NEMA 5-15	60	CAN, MEX, USA	None		

All crimpers are made for service in either country.

PC150HD Series Crimper

The PC150HD crimper is a compact engineered design to handle entry level low volumes in a shop environment. This crimper features a dial micrometer and with 240 tons of crimping force, has the capability to crimp up to 2" industrial hose.

The PC150HD standard package includes: Dial micrometer, foot switch, 84mm quick-change tool, 9 station die rack, manual back stop, protective master die foam pads, a Continental digital crimper and a mini grease gun with CRIMPX die lubricant grease.

FEATURES

- › Easy operating control system
- › Visible oil level through the sight glass and two oil drain ports
- › Compact design to fit in workshops and for on-site services
- › Complete range of dies and accessories available



Dial micrometer is fully adjustable providing speed, precision and repeatability.



Easy operating control system using the open/close green push button on the foot switch.



Manual back stop speeds multiple crimps of the same hose and fitting.



Easy grease maintenance through the 8 lubrication fittings.



Quick change tool makes die changes a quick and simple process.



1.5 hp motor & 2 hp motor are available.



PC150HD Series Crimper

CAPABILITY

- › 1/4" - 2" ID, B2's (braided hose) and up to 1 1/4" SG (6-spiral hose) with all coupling end styles and most bent tubes.

TECHNICAL DATA

CRIMPING FORCE 240 ton

WEIGHT 400 lbs. (crimper only)

DIMENSIONS 17 1/2" L x 25" W x 25" H

DIE SERIES PC150H

OIL CAPACITY 6 gallon



AVAILABLE CONFIGURATIONS

SAP #	Voltage	Phase	Plug	Hertz	Country Approved	Dies Included	Die Sizes (mm)	9-Station Die Rack Included
21053598	110V	1	NEMA 5-15	60	CAN, MEX, USA	12	16, 19, 23, 27, 31, 34, 41, 45, 50, 53, 56, 69	✓
21053599	220V	1	NEMA 6-20	60	CAN, MEX, USA	12	16, 19, 23, 27, 31, 34, 41, 45, 50, 53, 56, 69	✓

Contact customer service for PC150HDX 5HP option.



PC150HDX Series Crimper

The PC150HDX crimper is a compact engineered design to handle higher volumes in a shop environment. This crimper features a dial micrometer and with 240 tons of crimping force, has the capability to crimp up to 2" industrial hose.

The PC150HDX standard package includes: 5HP motor, dial micrometer, foot switch, 84mm quick-change tool, manual back stop, protective master die foam pads, spare set of die studs and QCT pins, Continental digital crimper and a mini grease gun with CRIMPX die lubricant grease.

FEATURES

BUILT-IN DIE STORAGE

- › The PC150HDX crimper has a built-in 5 die storage pockets panel to keep frequently used die sets readily available



Dial micrometer is fully adjustable, provides speed, precision and repeatability.



Quick change tool makes die changes a quick and simple process.



Manual back stop speeds multiple crimps of the same hose and fitting.



Easy grease maintenance through the 8 lubrication fittings.



9 station die rack included.



5 hp motor.

PC150HDX Series Crimper

CAPABILITY

- › 1/4" - 2" ID, B2's (braided hose) and up to 1 1/4" SG (6-spiral hose) with all coupling end styles and most bent tubes.

TECHNICAL DATA

CRIMPING FORCE 240 ton

WEIGHT 495 lbs. (crimper only)

DIMENSIONS 20" L x 29" W x 28" H

HYDRAULIC DIE SERIES PC150H

OIL CAPACITY 8 gallon



AVAILABLE CONFIGURATIONS

SAP #	Voltage	Phase	Plug	Hertz	Country Approved	Dies Included	Die Sizes (mm)	9-Station Die Rack Included
21157982	230V	1	NEMA L6-30P	60	CAN, MEX, USA	12	16, 19, 23, 27, 31, 34, 41, 45, 50, 53, 59, 62	✓
21157983	230V	3	NEMA L15-20P	60	CAN, MEX, USA	12	16, 19, 23, 27, 31, 34, 41, 45, 50, 53, 59, 62	✓
21157984	480V	3	NEMA L1620P	60	CAN, MEX, USA	12	16, 19, 23, 27, 31, 34, 41, 45, 50, 53, 59, 62	✓

PC200M Series Crimper

The PC200M crimper is a compact engineered design to handle higher volumes in a shop environment. With the dial micrometer and 340 tons of crimping force, it has the capability to crimp up to 3" industrial hose.

The PC200M standard package includes: Dial micrometer, foot switch, 99mm QCT, PC200 Rack, manual back stop, protective master die foam pads, 1 adapter die set, adapter die removal tool, spare set of die studs and QCT pins, Continental digital caliper, and mini grease gun w/ CRIMPX die lubricant grease tube.

FEATURES

PC200 RACK

- › The PC200M crimper comes with a 5 die storage pockets panel installed
- › The PC200M crimper can be mounted on top of the PC200 Rack
- › The PC200 Rack is a machine stand with 16 PC200 die storage pockets to keep frequently used die sets readily available



Dial micrometer is fully adjustable, provides speed, precision and repeatability.



Quick change tool makes die changes a quick and simple process.



Manual back stop speeds multiple crimps of the same hose and fitting.



Easy grease maintenance through the 8 lubrication fittings.



5 die storage pockets panel installed to keep frequently used die sets readily available.



The Foot switch permits dies to be "jogged" into position and keeps both hands free.

PC200M Series Crimper

CAPABILITY

- › 1/4" - 2" ID, 2-braid hose and 2" 6-spiral hose with all coupling end styles and most bent tubes

TECHNICAL DATA

CRIMPING FORCE 340 ton

WEIGHT 635 lbs. (crimper only)

DIMENSIONS 20" L x 29" W x 32" H

HYDRAULIC DIE SERIES PC200

ADAPTER DIE SERIES 130MM - 99MM

OIL CAPACITY 8 gallon



AVAILABLE CONFIGURATIONS

SAP #	Voltage	Phase	Plug	Hertz	Country Approved	Dies Included	Die Sizes (mm)	PC200 Rack Included
20442513	230V	1	NEMA L6-30P	60	CAN, MEX, USA	14	16, 19, 23, 27, 31, 34, 41, 45, 50, 53, 59, 62, 74, 78	✓
21095952	230V	3	NEMA L15-20P	60	CAN, MEX, USA	14	16, 19, 23, 27, 31, 34, 41, 45, 50, 53, 59, 62, 74, 78	✓
21095953	440-480V	3	NEMA L1620P	60	CAN, MEX, USA	14	16, 19, 23, 27, 31, 34, 41, 45, 50, 53, 59, 62, 74, 78	✓
21007698	24VDC	1	Jumper Cables	N/A	CAN, MEX, USA	14	16, 19, 23, 27, 31, 34, 41, 45, 50, 53, 59, 62, 74, 78	✓

Crim Cont



The future of crimping at your fingertips.

Continental introduces the new CrimplQ™ controller – the next generation, intelligent, cloud-based controller for hydraulic and industrial hose crimpers.

pio™

roller



PC160i Series with CrimpIQ™ Controller

The PC160i is a stationary crimper with more power to manufacture factory-quality hose assemblies quickly and easily. Featuring the Continental CrimpIQ™ Controller powered by Continental Fluid Solutions technology. This technology provides direct access to all crimping specifications and information. It supports a user-friendly interface to guide new and advanced users through the crimping process quickly and easily. Crimp settings, dwell time, pre-start positions and auto/manual operations are all easily set with electronic controls.

The PC160i standard package includes: 10-inch color capacitive touch screen, foot pedal, removable pusher, standard compression ring, WB press plate, spare set of springs and screws, Continental bluetooth caliper, vent plug, and CRIMPX die lubricant grease can w/ brush.

FEATURES

CrimpIQ® PRO Mode

- › 3 clicks to crimp
- › (-20) SG capability (w/ 53MM WB die)
- › Up to (-32) B2 Capability (only w/ WB dies)
- › Easy die removal process that enables the operator to change tooling quick, safe, and easy
- › Eliminates pain point of setting micrometer
- › Live crimp charts*
- › Integrated technical support*
- › Built-in crimp specifications
- › Advanced features like a Full-Automatic mode
- › 12 month subscription to CrimpCloud® included*

* When connected to Wi-Fi



Featuring CrimpIQ™ PRO mode, 3 clicks to crimp.



10-inch color capacitive touch screen and user friendly navigation.



Easy die set up.



Easy process that enables the operator to change tooling quick, safe, and easy.



CrimpIQ™ controller supports bluetooth calipers to input crimp diameter measurements.



New toggle switch for up and down (close and open) operation.

PC160i Series with CrimpIQ™ Controller

CAPABILITY

- › (-20) SG Fittings (w/ 53MM WB die)
- › (-32) B2 Fittings (only w/ WB dies)

TECHNICAL DATA

CRIMPING FORCE 160 ton

WEIGHT 400 lbs. (Crimper only)

DIMENSIONS 31¼" L x 16½" W x 33½" H

DIE SERIES PC160i / PC160i wide body

OIL CAPACITY 2 gallon



AVAILABLE CONFIGURATIONS

SAP #	Voltage	Phase	Plug	Hertz	Country Approved	Dies Included	Die Sizes (mm)	Die Shelf Included
21189471	220V	1	NEMA 6-20	60	CAN, MEX, USA	9	16, 19, 23, 27, 31, 34, 41, 45, 56	✓
21195466	220V	1	NEMA 6-20	60	CAN, MEX, USA	12	16, 19, 23, 27, 31, 34, 41, 45, 56, 53WB, 62WB, 69WB	✓
21195460	220V	1	NEMA 6-20	60	CAN, MEX, USA	11	16, 19, 23, 27, 31, 34, 41, 45, 56, 53WB, 69WB	✓
21189472	220V	1	NEMA 6-20	60	CAN, MEX, USA	None		

All crimpers are made for service in either country.

Crimpers

PC160i Series with CrimpIQ™ Controller

HYDRAULIC EQUIPMENT



PC200i Series with CrimpIQ™ Controller

The PC200i is a high-volume, high-capacity stationary crimper featuring the Continental CrimpIQ™ Controller powered by Continental Fluid Solutions technology. This technology provides direct access to all crimping specifications and information. It supports a user-friendly interface to guide new and advanced users through the crimping process quickly and easily. Crimp settings, dwell time, pre-start positions and auto/manual operations are all easily set with electronic controls.

The PC200i standard package includes: 10-inch color capacitive touch screen, foot switch, 99mm QCT, manual back stop, PC200 Rack, protective master die foam pads, 1 adapter die set, adapter die removal tool, spare set of die studs and QCT pins, Continental bluetooth digital caliper, and mini grease gun w/ CRIMPX die lubricant grease tube.

FEATURES

PC200 RACK

- › The PC200i crimper can be mounted on the PC200 Rack
- › The PC200 Rack is a machine stand with 16 PC200 die storage pockets to keep frequently used die sets readily available



Continental CrimpIQ™ controller, the future of crimping at your fingertips.



10-inch color capacitive touch screen and user friendly navigation.



Intuitive screens lead the operator through the setup and crimping process.



CrimpIQ™ controller supports bluetooth calipers to input crimp diameter measurements.



Easy grease maintenance through the 8 lubrication fittings.



Quick change tool makes die changes a quick and simple process.

PC200i Series with CrimpIQ™ Controller

CAPABILITY

- › 1/4" - 2" ID, 2-braid hose and 2" 6-spiral hose with all coupling end styles and most bent tubes

TECHNICAL DATA

CRIMPING FORCE 340 ton

WEIGHT 635 lbs. (crimper only)

DIMENSIONS 20" L x 29" W x 32" H

HYDRAULIC DIE SERIES PC200

ADAPTER DIE SERIES 130MM - 99MM

OIL CAPACITY 8 gallon



AVAILABLE CONFIGURATIONS

SAP #	Voltage	Phase	Plug	Hertz	Country Approved	Dies Included	Die Sizes (mm)	PC200 Rack Included
21006081	230V	1	NEMA L6-30P	60	MEX, USA	14	16, 19, 23, 27, 31, 34, 41, 45, 50, 53, 59, 62, 74, 78	✓
21006080	230V	3	NEMA L15-20P	60	MEX, USA	14	16, 19, 23, 27, 31, 34, 41, 45, 50, 53, 59, 62, 74, 78	✓
21006011	440-480V	3	NEMA L16-20P	60	MEX, USA	14	16, 19, 23, 27, 31, 34, 41, 45, 50, 53, 59, 62, 74, 78	✓
21006082	230V	1	NEMA L6-30P	60	CANADA	14	16, 19, 23, 27, 31, 34, 41, 45, 50, 53, 59, 62, 74, 78	✓
21006083	230V	3	NEMA L1530-P	60	CANADA	14	16, 19, 23, 27, 31, 34, 41, 45, 50, 53, 59, 62, 74, 78	✓
21006013	575V	3	Not Supplied	60	CANADA	14	16, 19, 23, 27, 31, 34, 41, 45, 50, 53, 59, 62, 74, 78	✓
21006005	230V	1	NEMA L6-30P	60	MEX, USA	None		✓
21006000	230V	3	NEMA L15-20P	60	MEX, USA	None		✓

Crimpers

PC200i Series with CrimpIQ™ Controller

HYDRAULIC EQUIPMENT



PC440i Series with CrimpIQ™ Controller

The PC440i features the Continental CrimpIQ™ Controller powered by Continental Fluid Solutions technology, providing direct access to all crimping specifications and information. It supports a user-friendly interface to guide new and advanced users through the crimping process quickly and easily. The PC440i can track the number of crimps and automatically pause for a quality-check at preset intervals. Its pressure transducer monitors crimping “effort” eliminating trial-and-error crimping.

The PC440i standard package includes: 10-inch color capacitive touch screen, adjustable mirror, foot switch, 99mm QCT, manual back stop, (1) adapter die set, adapter die removal T-handle hex, spare of die studs and QCT pins, Continental bluetooth digital caliper, and mini grease gun w/ CRIMPX die lubricant grease tube.

FEATURES

BUILT-IN DIE STORAGE

- › The PC440i crimper comes with 12 PC200 die storage pockets to keep frequently used die sets readily available

MANUAL BACK STOP

- › The manual back stop speeds multiple crimps of the same hose and fitting

GREASE MAINTENANCE

- › The lubrications fittings on the crimper makes grease maintenance easier to keep the crimper lubricated for a good performance



Continental CrimpIQ™ controller, the future of crimping at your fingertips.



10-inch color capacitive touch screen and user friendly navigation.



Intuitive screens lead the operator through the setup and crimping process.



CrimpIQ™ controller supports bluetooth calipers to input crimp diameter measurements.



Quick change tool makes die changes a quick and simple process.



Fixed 6 o'clock die position allows the operator to place the fitting on bottom die and crimp.

PC440i Series with CrimpIQ™ Controller

CAPABILITY

- › 1/4" - 2" ID, 2-braid hose and 2" 6-spiral hose and 4" industrial hose with all coupling end styles and most bent tubes
- › 1/2" - 4" ID industrial hose

TECHNICAL DATA

CRIMPING FORCE 265 ton

WEIGHT 1,840 lbs. (crimper only)

DIMENSIONS 46 1/2" L x 52" W x 67" H

HYDRAULIC DIE SERIES PC200

ADAPTER DIE SERIES 160MM - 99MM

INDUSTRIAL DIE SERIES 160S

OIL CAPACITY 24 gallon



AVAILABLE CONFIGURATIONS

SAP #	Voltage	Phase	Plug	Hertz	Country Approved	Dies Included	Die Sizes (mm)	Die Shelf Included
21006084	230V	1	NEMA L6-30P	60	CAN, MEX, USA	14	16, 19, 23, 27, 31, 34, 41, 45, 50, 53, 59, 62, 74, 78	✓
21006085	230V	3	NEMA L15-20P	60	CAN, MEX, USA	14	16, 19, 23, 27, 31, 34, 41, 45, 50, 53, 59, 62, 74, 78	✓
21095954	480V	3	NEMA L16-20P	60	CAN, MEX, USA	14	16, 19, 23, 27, 31, 34, 41, 45, 50, 53, 59, 62, 74, 78	✓
21006007	230V	1	NEMA L6-30P	60	CAN, MEX, USA	None		✓
21006002	230V	3	NEMA L15-20P	60	CAN, MEX, USA	None		✓

Crimpers

PC400i Series with CrimpIQ™ Controller

HYDRAULIC EQUIPMENT



PC600i Series with CrimpIQ™ Controller

The PC600i is a high-volume, high-capacity stationary crimper featuring the Continental CrimpIQ™ Controller powered by Continental Fluid Solutions technology. This technology provides direct access to all crimping specifications and information. It supports a user-friendly interface to guide new and advanced users through the crimping process quickly and easily. The PC600i can produce 2,200 crimps per hour with 350 tons of crimping force to allow for both hydraulic and industrial hose assemblies.

The PC600i standard package includes: 10-inch color capacitive touch screen, adjustable mirror, foot switch, 99mm QCT, manual back stop, 1 adapter die set, adapter die removal T-handle hex, spare set of die studs and QCT pins, Continental bluetooth digital caliper, and mini grease gun w/ CRIMPX die lubricant grease tube.

FEATURES

BUILT-IN DIE STORAGE

- › The PC600i crimper comes with 16 PC200 die storage pockets and 6 industrial die storage shelves to keep frequently used die sets readily available

MANUAL BACK STOP

- › The manual back stop speeds multiple crimps of the same hose and fitting

GREASE MAINTENANCE

- › The lubrications fittings on the crimper makes grease maintenance easier to keep the crimper lubricated for a good performance



Continental CrimpIQ™ controller, the future of crimping at your fingertips.



10-inch color capacitive touch screen and user friendly navigation.



Intuitive screens lead the operator through the setup and crimping process.



CrimpIQ™ controller supports bluetooth calipers to input crimp diameter measurements.



Quick change tool makes die changes a quick and simple process.



Use the foot pedal to close the crimper head when crimping in semi and full automatic mode.

PC600i Series with CrimpIQ™ Controller

CAPABILITY

- › 1/4" - 2 1/2" ID, 2-braid and 6-spiral hydraulic hose
- › 3/16" - 6" ID industrial hose

TECHNICAL DATA

CRIMPING FORCE 350 ton

WEIGHT 4,000 lbs. (crimper only)

DIMENSIONS 49" L x 54" W x 69" H

HYDRAULIC DIE SERIES PC200

ADAPTER DIE SERIES 160MM - 99MM

INDUSTRIAL DIE SERIES 160 OB

OIL CAPACITY 24 gallon



AVAILABLE CONFIGURATIONS

SAP #	Voltage	Phase	Plug	Hertz	Country Approved	Dies Included	Die Sizes (mm)	Die Shelf Included
21006089	230V	1	NEMA L6-30P	60	CAN, MEX, USA	22	16, 19, 23, 27, 31, 34, 41, 45, 50, 53, 59, 62, 74, 78, 84, 92, 100, 108, 116, 126, 166, 178	✓
21006088	230V	3	NEMA L15-20P	60	CAN, MEX, USA	22	16, 19, 23, 27, 31, 34, 41, 45, 50, 53, 59, 62, 74, 78, 84, 92, 100, 108, 116, 126, 166, 178	✓
21006090	440-480V	3	NEMA L16-20P	60	CAN, MEX, USA	22	16, 19, 23, 27, 31, 34, 41, 45, 50, 53, 59, 62, 74, 78, 84, 92, 100, 108, 116, 126, 166, 178	✓
21006087	230V	1	NEMA L6-30P	60	CAN, MEX, USA	14	16, 19, 23, 27, 31, 34, 41, 45, 50, 53, 59, 62, 74, 78	✓
21006086	230V	3	NEMA L15-20P	60	CAN, MEX, USA	14	16, 19, 23, 27, 31, 34, 41, 45, 50, 53, 59, 62, 74, 78	✓
21006021	440-480V	3	NEMA L16-20P	60	CAN, MEX, USA	14	16, 19, 23, 27, 31, 34, 41, 45, 50, 53, 59, 62, 74, 78	✓
21006008	230V	1	NEMA L6-30P	60	CAN, MEX, USA	None		✓
21006003	230V	3	NEMA L15-20P	60	CAN, MEX, USA	None		✓

Crimpers

PC600i Series with CrimpIQ™ Controller

HYDRAULIC EQUIPMENT



PC1000i Series with CrimpIQ™ Controller

The PC1000i is a high-volume, high-capacity stationary crimper featuring the Continental CrimpIQ™ Controller powered by Continental Fluid Solutions technology. This technology provides direct access to all crimping specifications and information. It supports a user-friendly interface to guide new and advanced users through the crimping process quickly and easily. The PC1000i can produce 1,415 crimps per hour with 485 tons of crimping force to allow for both hydraulic and industrial hose assemblies and is ideal for production assembly applications.

The PC1000i standard package includes: 10-inch color capacitive touch screen, adjustable mirror, foot switch, 99mm QCT, manual back stop, 2 adapter die sets, adapter die removal T-handle hex, spare set of die studs and QCT pins, Continental bluetooth digital caliper, and mini grease gun w/ CRIMPX die lubricant grease tube.

FEATURES

BUILT-IN DIE STORAGE

- › The PC1000i crimper comes with 15 PC200 die storage pockets and 10 industrial die storage shelves to keep frequently used die sets readily available

MANUAL BACK STOP

- › The manual back stop speeds multiple crimps of the same hose and fitting

GREASE MAINTENANCE

- › The lubrications fittings on the crimper makes grease maintenance easier to keep the crimper lubricated for a good performance



Continental CrimpIQ™ controller, the future of crimping at your fingertips.



10-inch color capacitive touch screen and user friendly navigation.



Intuitive screens lead the operator through the setup and crimping process.



CrimpIQ™ controller supports bluetooth calipers to input crimp diameter measurements.



Quick change tool makes die changes a quick and simple process.



Use the foot pedal to close the crimper head when crimping in semi and full automatic mode.

PC1000i Series with CrimpIQ™ Controller

CAPABILITY

- › Up to 2 ½" ID, 2-braided, 4-spiral and 6-spiral hydraulic hose
- › 3/16" - 10" ID industrial hose

TECHNICAL DATA

CRIMPING FORCE 485 ton

WEIGHT 6,185 lbs. (crimper only)

CRIMPER DIMENSIONS 54" L x 62" W x 86" H

POWER UNIT DIMENSIONS 28" L x 33 ½" W x 45" H

HYDRAULIC DIE SERIES PC200

ADAPTER DIE SERIES 230MM - 145MM
145MM - 99MM

INDUSTRIAL DIE SERIES 230 OB

OIL CAPACITY 45 gallon



AVAILABLE CONFIGURATIONS

SAP #	Voltage	Phase	Plug	Hertz	Country Approved	Dies Included	Die Sizes (mm)	Die Shelf Included
21071067	230V	1	NEMA L6-30P	60	CAN, MEX, USA	24	16, 19, 23, 27, 31, 34, 41, 45, 50, 53, 59, 62, 74, 78, 84, 92, 100, 108, 116, 126, 166, 178, 215, 245	✓
21006091	230V	3	NEMA L15-20P	60	CAN, MEX, USA	24	16, 19, 23, 27, 31, 34, 41, 45, 50, 53, 59, 62, 74, 78, 84, 92, 100, 108, 116, 126, 166, 178, 215, 245	✓
21006009	230V	1	NEMA L6-30P	60	CAN, MEX, USA	None		✓
21006004	230V	3	NEMA L15-20P	60	CAN, MEX, USA	None		✓

Crimpers

PC1000i Series with CrimpIQ™ Controller

HYDRAULIC EQUIPMENT



PC1200i Series with CrimpIQ™ Controller

The PC1200i is a high-volume, high-capacity stationary crimper featuring the Continental CrimpIQ™ Controller powered by Continental Fluid Solutions technology. This technology provides direct access to all crimping specifications and information. It supports a user-friendly interface to guide new and advanced users through the crimping process quickly and easily. The PC1200i can produce 830 tons of crimping force to allow for both hydraulic and industrial hose assemblies and is ideal for production assembly applications.

The PC1200i standard package includes: 10-inch color capacitive touch screen, foot switch, 99mm QCT, 3 adapter die sets, adapter die removal T-handle hex, spare set of die studs and QCT pins, Continental bluetooth digital caliper, and large grease gun w/ CRIMPX die lubricant grease tube.

FEATURES

BUILT-IN DIE STORAGE CABINETS

- › The PC1200i crimper comes with front and back die storage cabinets
- › 15 PC200 die storage pockets and 16 industrial die storage shelves to keep frequently used die sets readily available or any crimping accessories

GREASE MAINTENANCE

- › The lubrications fittings on the crimper makes grease maintenance easier to keep the crimper lubricated for a good performance



Continental CrimpIQ™ controller, the future of crimping at your fingertips.



10-inch color capacitive touch screen and user friendly navigation.



Intuitive screens lead the operator through the setup and crimping process.



CrimpIQ™ controller supports bluetooth calipers to input crimp diameter measurements.



Quick change tool makes die changes a quick and simple process.



Use the foot pedal to close the crimper head when crimping in semi and full automatic mode.

PC1200i Series with CrimpIQ™ Controller

CAPABILITY

- › Up to 2 ½" ID, 2-braided, 4-spiral and 6-spiral hydraulic hose
- › 3/16" - 12" ID industrial hose

TECHNICAL DATA

CRIMPING FORCE 830 ton

WEIGHT 10,000 lbs. (crimper only)

CRIMPER DIMENSIONS 60" L x 56" W x 78" H

POWER UNIT DIMENSIONS 36" L x 48" W x 60" H

HYDRAULIC DIE SERIES PC200

ADAPTER DIE SERIES 330MM - 230MM
230MM - 160MM
160MM - 99MM

INDUSTRIAL DIE SERIES 160S/230XL/330S/330-OB

OIL CAPACITY 80 gallon



AVAILABLE CONFIGURATIONS

SAP #	Voltage	Phase	Plug	Hertz	Country Approved	Dies Included	Die Sizes (mm)	Die Shelf Included
21023980	440-480V	3	NEMA L16-20P	60	*CAN, MEX, USA	25	41, 45, 50, 53, 56, 62, 69, 75, 74, 78, 84, 92, 100, 108, 116, 126, 166, 178, 190, 215, 245, 281, 311, 333, 349	✓

*CSA rated components are being used, but CSA decal isn't applied.

Crimpers

PC1200i Series with CrimpIQ™ Controller

HYDRAULIC EQUIPMENT







Crimper Quick Info Chart





















Model	SAP #	Crimping Capability	Crimping Force	Pump	PSI	Reservoir Capacity	Voltage	Phase	Plug
 PC100S-RCD	21063190	(-16) 	35 Tons	Pneumatic	10,000	100 in ³ (1,639 cc)			
	21063169	(-08) 	35 Tons	Hand	N/A	25 in ³ (1,410 cc)			
 PC125M-RCD	20821205	(-20) 	60 Tons	None	N/A	N/A			
	20821204	(-16) 	60 Tons	None	N/A	N/A			
 PC120M	21151022	(-16)  (-12) 	120 Tons	None	N/A	N/A			
 PC125-RCD	20809573	(-20) 	60 Tons			1 Gallon	110V	1	NEMA 5-15
	20969061	(-16) 	60 Tons			1 Gallon	220V	1	NEMA 6-20
	20809571		60 Tons			1 Gallon	110V	1	NEMA 5-15
 PC150HD	21053598	(-32) 	240 Tons			6 Gallons	110V	1	NEMA 5-15
	21053599	(-20) 	240 Tons			6 Gallons	220V	1	NEMA 6-20
 PC150HDX	21157982	(-32) 	240 Tons			8 Gallons	230V	1	NEMA L6-30P
	21157983		240 Tons			8 Gallons	230V	3	NEMA L15-20P
	21157984	(-20) 	240 Tons			8 Gallons	480V	3	NEMA L1620
 PC200M	20442513	(-32) 	340 Tons			8 Gallons	230V	1	NEMA L6-30P
	21095952	(-32) 	340 Tons			8 Gallons	230V	3	NEMA L15-20P
	21095953	(-32) 	340 Tons			8 Gallons	440-480V	3	NEMA L1620P
	21007698		340 Tons			8 Gallons	24VDC	1	jumper Cables
 PC160i	21189470		160 Tons			2 Gallons	220V	1	NEMA 6-20
	21189471	(-32) 	160 Tons			2 Gallons	220V	1	NEMA 6-20
	21195466	(-20) 	160 Tons			2 Gallons	220V	1	NEMA 6-20
	21195460		160 Tons			2 Gallons	220V	1	NEMA 6-20
	21189472		160 Tons			2 Gallons	220V	1	NEMA 6-20

*Note: WB Dies required



Crimper Quick Info Chart

Hertz	Country Approved	Dies Included	Die Sizes (mm)	Quick Disconnect Included	Die Storage Included	Available Shop In A Box
	CAN, MEX, USA	7	12, 16, 19, 23, 27, 31, 43	✓	Drawer / Stand	
	CAN, MEX, USA	7	12, 16, 19, 23, 27, 31, 43	✓	Drawer / Stand	
	CAN, MEX, USA	8	16, 19, 23, 27, 31, 34, 43, 50	✓	Drawer / Stand	
	CAN, MEX, USA	None		✓		
	CAN, MEX, USA	6	16, 19, 23, 27, 31, 37	✓	Die carrying case	
60	CAN, MEX, USA	8	16, 19, 23, 27, 31, 34, 43, 50		Drawer / Stand	
60	CAN, MEX, USA	8	16, 19, 23, 27, 31, 34, 43, 50		Drawer / Stand	
60	CAN, MEX, USA	None				
60	CAN, MEX, USA	12	16, 19, 23, 27, 31, 34, 41, 45, 50, 53, 56, 69		9 Station Die Rack	
60	CAN, MEX, USA	12	16, 19, 23, 27, 31, 34, 41, 45, 50, 53, 56, 69		9 Station Die Rack	
60	CAN, MEX, USA	12	16, 19, 23, 27, 31, 34, 41, 45, 50, 53, 59, 62		9 Station Die Rack	
60	CAN, MEX, USA	12	16, 19, 23, 27, 31, 34, 41, 45, 50, 53, 59, 62		9 Station Die Rack	
60	CAN, MEX, USA	12	16, 19, 23, 27, 31, 34, 41, 45, 50, 53, 59, 62		9 Station Die Rack	
60	CAN, MEX, USA	14	16, 19, 23, 27, 31, 34, 41, 45, 50, 53, 59, 62, 74, 78		PC200 Rack	
60	CAN, MEX, USA	14	16, 19, 23, 27, 31, 34, 41, 45, 50, 53, 59, 62, 74, 78		PC200 Rack	
60	CAN, MEX, USA	14	16, 19, 23, 27, 31, 34, 41, 45, 50, 53, 59, 62, 74, 78		PC200 Rack	
N/A	CAN, MEX, USA	14	16, 19, 23, 27, 31, 34, 41, 45, 50, 53, 59, 62, 74, 78		PC200 Rack	
60	CAN, MEX, USA	10	16, 19, 23, 27, 31, 34, 41, 45, 56, 53WB		Die Shelf	
60	CAN, MEX, USA	9	16, 19, 23, 27, 31, 34, 41, 45, 56		Die Shelf	
60	CAN, MEX, USA	12	16, 19, 23, 27, 31, 34, 41, 45, 56, 53WB, 62WB, 69WB		Die Shelf	
60	CAN, MEX, USA	11	16, 19, 23, 27, 31, 34, 41, 45, 56, 53WB, 69WB		Die Shelf	
60	CAN, MEX, USA	None				

Crimper Quick Info Chart

Model	SAP #	Crimping Capability	Crimping Force	Reservoir Capacity	Voltage	Phase	Plug	
 PC200i	21006081	(-32) 	340 Tons	8 Gallons	230V	1	NEMA L6-30P	
	21006080		340 Tons	8 Gallons	230V	3	NEMA L15-20P	
	21006011		340 Tons	8 Gallons	440-480V	3	NEMA L16-20P	
		21006082	(-32) 	340 Tons	8 Gallons	230V	1	NEMA L6-30P
		21006083		340 Tons	8 Gallons	230V	3	NEMA L1530-P
		21006013		340 Tons	8 Gallons	575V	3	Not Supplied
		21006005	(-32) 	340 Tons	8 Gallons	230V	1	NEMA L6-30P
		21006000		340 Tons	8 Gallons	230V	3	NEMA L15-20P
 PC440i	21006084		265 Tons	24 Gallons	230V	1	NEMA L6-30P	
	21006085	(-32) 	265 Tons	24 Gallons	230V	3	NEMA L15-20P	
	21095954	(-32) 						
	21006007	(-24) 	265 Tons	24 Gallons	480V	3	NEMA L16-20P	
	21006002	4" Industrial Hose	265 Tons	24 Gallons	230V	1	NEMA L6-30P	
		265 Tons	24 Gallons	230V	3	NEMA L15-20P		
 PC600i	21006089	(-32) 	350 Tons	24 Gallons	230V	1	NEMA L6-30P	
	21006088	(-32) 	350 Tons	24 Gallons	230V	3	NEMA L15-20P	
	21006090	(-32) 	350 Tons	24 Gallons	440-480V	3	NEMA L16-20P	
	21006087	(-32) 	350 Tons	24 Gallons	230V	1	NEMA L6-30P	
	21006086	(-40) DGF1	350 Tons	24 Gallons	230V	3	NEMA L15-20P	
	21006021	(-48) UCFB2	350 Tons	24 Gallons	440-480V	3	NEMA L16-20P	
	21006008	6" industrial Hose	350 Tons	24 Gallons	230V	1	NEMA L6-30P	
	21006003		350 Tons	24 Gallons	230V	3	NEMA L15-20P	
 PC1000i	21071067	(-32) 	485 Tons	45 Gallons	230V	1	NEMA L6-30P	
	21006091	(-32) 	485 Tons	45 Gallons	230V	3	NEMA L15-20P	
	21006009	(-32) 	485 Tons	45 Gallons	230V	1	NEMA L6-30P	
	21006004	(-40) DGF1 (-48) UCFB2 10" Industrial Hose	485 Tons	45 Gallons	230V	3	NEMA L15-20P	
 PC1200i	21023980	(-32)  (-32)  (-32)  (-40) DGF1 (-48) UCFB2 12" Industrial Hose	830 Tons	80 Gallons	440-480V	3	NEMA L16-20P	

Crimper Quick Info Chart

Hertz	Country Approved	Dies Included	Die Sizes (mm)	Die Storage Included	Available Shop In A Box
60	MEX, USA	14	16, 19, 23, 27, 31, 34, 41, 45, 50, 53, 59, 62, 74, 78	PC200 Rack	
60	MEX, USA	14	16, 19, 23, 27, 31, 34, 41, 45, 50, 53, 59, 62, 74, 78	PC200 Rack	
60	MEX, USA	14	16, 19, 23, 27, 31, 34, 41, 45, 50, 53, 59, 62, 74, 78	PC200 Rack	
60	CANADA	14	16, 19, 23, 27, 31, 34, 41, 45, 50, 53, 59, 62, 74, 78	PC200 Rack	
60	CANADA	14	16, 19, 23, 27, 31, 34, 41, 45, 50, 53, 59, 62, 74, 78	PC200 Rack	
60	CANADA	14	16, 19, 23, 27, 31, 34, 41, 45, 50, 53, 59, 62, 74, 78	PC200 Rack	
60	MEX, USA	None		PC200 Rack	
60	MEX, USA	None		PC200 Rack	
60	CAN, MEX, USA	14	16, 19, 23, 27, 31, 34, 41, 45, 50, 53, 59, 62, 74, 78	Die Shelf	
60	CAN, MEX, USA	14	16, 19, 23, 27, 31, 34, 41, 45, 50, 53, 59, 62, 74, 78	Die Shelf	
60	CAN, MEX, USA	14	16, 19, 23, 27, 31, 34, 41, 45, 50, 53, 59, 62, 74, 78	Die Shelf	
60	CAN, MEX, USA	None		Die Shelf	
60	CAN, MEX, USA	None		Die Shelf	
60	CAN, MEX, USA	22	16, 19, 23, 27, 31, 34, 41, 45, 50, 53, 59, 62, 74, 78, 84, 92, 100, 108, 116, 126, 166, 178	Die Shelf	
60	CAN, MEX, USA	22	16, 19, 23, 27, 31, 34, 41, 45, 50, 53, 59, 62, 74, 78, 84, 92, 100, 108, 116, 126, 166, 178	Die Shelf	
60	CAN, MEX, USA	22	16, 19, 23, 27, 31, 34, 41, 45, 50, 53, 59, 62, 74, 78, 84, 92, 100, 108, 116, 126, 166, 178	Die Shelf	
60	CAN, MEX, USA	14	16, 19, 23, 27, 31, 34, 41, 45, 50, 53, 59, 62, 74, 78	Die Shelf	
60	CAN, MEX, USA	14	16, 19, 23, 27, 31, 34, 41, 45, 50, 53, 59, 62, 74, 78	Die Shelf	
60	CAN, MEX, USA	14	16, 19, 23, 27, 31, 34, 41, 45, 50, 53, 59, 62, 74, 78	Die Shelf	
60	CAN, MEX, USA	None		Die Shelf	
60	CAN, MEX, USA	None		Die Shelf	
60	CAN, MEX, USA	24	16, 19, 23, 27, 31, 34, 41, 45, 50, 53, 59, 62, 74, 78, 84, 92, 100, 108, 116, 126, 166, 178, 215, 245	Die Shelf	
60	CAN, MEX, USA	24	16, 19, 23, 27, 31, 34, 41, 45, 50, 53, 59, 62, 74, 78, 84, 92, 100, 108, 116, 126, 166, 178, 215, 245	Die Shelf	
60	CAN, MEX, USA	None		Die Shelf	
60	CAN, MEX, USA	None		Die Shelf	
60	CAN, MEX, USA	25	41, 45, 50, 53, 56, 62, 69, 75, 74, 78, 84, 92, 100, 108, 116, 126, 166, 178, 190, 215, 245, 281, 311, 333, 349	Die Shelf	

Smart Test Bench Controller Test Benches

Whether you are producing a single assembly or a production run, Continental has the test equipment to give both you and your customer the assurance that the product has been assembled correctly. The smart controller gives the operator the ability to pre-program and repeat a test sequence, then save the results to USB.

CUSTOMIZED AND SPECIAL DESIGN BENCHES

In addition to the standard Electronic “Smart Test Bench Controller” series, special purpose test benches can be designed by our engineering department, as well as an extension trough can be designed to meet specific requirements.

FEATURES

- › User-friendly system features an intuitive touch-screen panel that greatly improves control over testing parameters
- › Configurable design to test low pressure industrial or high pressure hydraulic hoses
- › Advanced reporting and printable test reports
- › Configurable data parameters to provide detailed information to your customer
- › Cloud connected for backups and reporting



10-inch color capacitive touch screen and user friendly navigation.



Additional keyboard for user-friendly navigation.

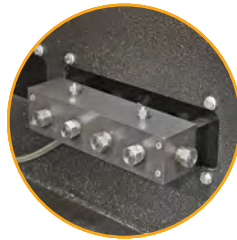

Multi-Port Manifold Outlet, allows multiple hose assemblies to be tested at the same time.



Safety Switch activates and drops pressure as soon as the lid is opened.



Removable side panel permits the testing of longer hose assemblies with the attachment of an optional trough.



Available extension trough in 10 foot sections.

Smart Test Bench Controller Test Benches

CAPABILITY

Standard Test Benches

- › C-IQ-1500 – Test pressure range to 21,500 psi (1,500 bar)
- › C-IQ-2500 – Test pressure range to 37,500 psi (2,500 bar)
- › C-IQ-3500 – Test pressure range to 50,000 psi (3,500 bar)

Industrial Test Benches

- › C-IQ-350/1500 – Test pressure range to 21,500 psi (1,500 bar)
- › C-IQ-350/2500 – Test pressure range to 37,500 psi (2,500 bar)
- › C-IQ-350/3500 – Test pressure range to 50,000 psi (3,500 bar)
- › C-IQ-350 – Test pressure range to 5,000 psi (350 bar)

TECHNICAL DATA

WEIGHT 1,236 lbs.

INSIDE CABINET DIMENSIONS
67" L x 33" W x 17" H

OVERALL CABINET DIMENSIONS

Standard Test Bench
99 ½" L x 39" W x 78" H (closed 52" H)

Industrial Test Bench
112 ½" L x 50" W x 84" H (closed 65" H)



AVAILABLE CONFIGURATIONS

SAP #	Model	Cabinet Size	Voltage	Phase	Plug	Hertz	Country Approved	Maximum Pressure	Minimum Test Pressure	Flowjet Booster Pump Included
21163029	C-IQ-1500	STANDARD	110V	1	NEMA 5-15	50/60	*CAN, MEX, USA	21,500 psi	**1,000 psi	✓
21163030	C-IQ-2500	STANDARD	110V	1	NEMA 5-15	50/60	*CAN, MEX, USA	37,500 psi	**1,250 psi	✓
21163031	C-IQ-3500	STANDARD	110V	1	NEMA 5-15	50/60	*CAN, MEX, USA	50,000 psi	**1,500 psi	✓
21163032	C-IQ-350/1500	INDUSTRIAL	110V	1	NEMA 5-15	50/60	*CAN, MEX, USA	21,500 psi	**125 psi	✓
21163033	C-IQ-350/2500	INDUSTRIAL	110V	1	NEMA 5-15	50/60	*CAN, MEX, USA	37,500 psi	**125 psi	✓
21163034	C-IQ-350/3500	INDUSTRIAL	110V	1	NEMA 5-15	50/60	*CAN, MEX, USA	50,000 psi	**125 psi	✓
21163035	C-IQ-350	INDUSTRIAL	110V	1	NEMA 5-15	50/60	*CAN, MEX, USA	5,000 psi	**125 psi	✓

*CSA rated components are being used, but CSA decal isn't applied.

**Minimum volumes must be tested.

Test Benches

Smart Test Bench Controller Series

HYDRAULIC EQUIPMENT



New CrimplIQ™ Controller Retro-Fit Kit

Still using a crimper with the old ACT™ Controller? Now there's a better way.

With the CrimplIQ™ Retro-Fit Kit you can upgrade your crimper technology to our cloud-based controller.

Continental introduces the new CrimplIQ™ Controller Retro-Fit Kit for the PC200 and PC400 Crimpers. Upgrade your PC200/PC400 crimper with the new CrimplIQ™ Controller and discover the crimping technology at your fingertips. The CrimplIQ™ Controller software is cloud-based and can provide instant information to owners. Wi-Fi is required. The Retro-Fit Kit standard package includes: tablet panel, PLC, connection cable, bluetooth caliper, 1/8" hex key, test crimp hose assembly, (4) front panel bolts, and (6) tablet panel screws.



CrimplIQ™ Controller Retro-Fit Kit

FUNCTIONALITY

- › Easy to use interface, on a 10-inch color capacitive touch screen
- › Daily reports*
- › Remote downloading of updated crimp specifications*
- › Favorite thousands of crimp details
- › Security - end-to-end data encryption from tablet to cloud
- › Operators only have access to essential crimp applications

OPERATIONALITY

- › Bluetooth calipers provided with each crimper
- › User accounts track operations to individual team members
- › Remote troubleshooting*
- › In-depth training and tutorial guides
- › Video support*

LONGEVITY

- › Preventative maintenance alerts
- › Full controller backup to the cloud*
- › Future enhancements through cloud updates*

*Requires Wi-Fi connection



Continental CrimplIQ™ controller, the future of crimping at your fingertips.



10-inch color capacitive touch screen and user friendly navigation.



Intuitive screens lead the operator through the setup and crimping process.



CrimplIQ™ controller supports bluetooth calipers to input crimp diameter measurements.

Included in the Standard Package

SAP #	Tablet Panel	PLC	Connection Cable	Bluetooth Caliper	1/8" Hex Key	2 Test Crimp Fittings	4 Front Panel Bolts	6 Tablet Panel Screws	Die Decal Kit
21043733	✓	✓	✓	✓	✓	✓	✓	✓	✓

Contact customer service for field upgrades for: PC440/PC600/PC1000/PC1200



CrimpCloud® Management & Traceability

Efficiency And Safety Have Never Been Smarter



The Connected Solution That Takes
Your Hose Operation To The Next Level

Combining the power of our CrimpIQ™ crimpers with CrimpCloud® greatly increases the efficiency of your operation, delivers real-time traceability and improves the quality and safety of every crimp. Whether your hose assembly operation is small or large, here's why you should upgrade to the CrimpCloud® solutions.



IMPROVED PRODUCTIVITY

Improved equipment maintenance, support, integrated e-resources, reports and equipment utilization data.



TRACEABILITY

Monitor production data and create birth certificates for every hose assembly for full traceability.



QUALITY CONTROL

Track machine performance, ensure crimp quality and eliminate errors.



CrimpCloud® Traceability

Everything You Need to Know

What is CrimpCloud® Traceability Solution? CrimpCloud® is a software that connects equipment and people to build a quality hose assembly every time. With this new solution, we're confident we can take your operations to the next level! Traceability is a key function of the application. The unique hose identification allows you to track both assembly and operations-related information. Record, manage, and retrieve information that is important to you. With a proper identification system, downtime can be avoided. Assets can be identified quickly, and replacement products can be sourced in a much shorter time at lower cost.

How can I access CrimpCloud® Traceability? In order to access CrimpCloud's traceability solutions, you need to be a Continental-approved partner. You can either go to our site, www.crimpcloud.com to register or send an email to crimpcloud@continental.com. For the best user experience, we propose using Google Chrome™ browser. Internet connection is required. Visit crimpcloud.com to learn more about CrimpCloud® software. Feel free to reach out to our sales representatives or customer service for more information.

How can I look up hoses with the ID?

There are two ways to identify the hose assembly. Either you scan the QR code with your smart phone or you enter the alphanumeric code at www.crimpcloud.com. Either way, you will get the same information.

Is my data safe?

Absolutely. We use industry leading security to protect your information. Data transferred is secured using standard encryption. You can find our Data Policy and Terms of Service at www.crimpcloud.com.

CrimpCloud® Traceability

Everything You Need to Know



Is this only for Continental hoses?

Our traceability solution is not designed only for Continental hoses. It is a flexible solution to any assets that could be tagged. However, you can get the best return on the investment if you use all features of CrimpCloud® that come along with the traceability program.

What information is on the label?

We designed the labels to contain information about the assembly and fabricator.

YOUR LOGO — Customizable logo

ID
XXXXX-XXXXXXXXX — Unique QR code and asset ID

Assembled
09/20/2021

For immediate replacement:
(330) 664-7000 — Call to action for immediate replacement

Customer Part Number:
HHA-01-PUMP#02 — End user Part Number

Powered by CrimpCloud.com

Continental
WWSM2-SUBORD
Test Part
5000 PSI

CrimpCloud®
Scan this code for more information.

We can customize labels to include your logo. Feel free to send us your logo and we will design the label for you. Maximum logo size should be: 1000px by 1000px, or 5MB. As for the thermal print technology, we can only use black color.

Do I need to have a CrimpIQ® crimper?

No, you do not. You can access CrimpCloud® via a standard internet browser. CrimpCloud® was developed as a versatile hose assembly software. You can get the biggest benefits if you use our connected equipment powered by our CrimpIQ® Technologies.

What is the size of the label?

The labels provide an optimum solution for hydraulic hoses 1-¼" ID or smaller. The label consists of the printable area and the transparent tail that should be wrapped around the printable area for protection. The labels are 2" wide and 6" long including the 2" printable area. Labels (Part number: 21135991) come on a roll with 750 pieces. Minimum Order Quantity is 3 rolls.

What about the printer?

Just like with the labels, we have worked with Zebra, an industry leader in printing. Our current solutions have been developed and optimized for Zebra printers. As a result of our testing and development process, the best labeling experience can be achieved utilizing the Zebra ZT231 Thermal Transfer Industrial Printer. If you don't already have a compatible Zebra printer, we offer them alongside the labels. Feel free to reach out to us to get pricing and delivery time information. Stock varies, and we have different, tested models from the ZT231 series. If you already have a Zebra printer, get in touch with us to validate the compatibility. We also created a starter kit to make ordering easy and provide a turnkey option if required.

CHOOSE FROM TWO TIERS OF ACCESS



Each tier has an annual subscription price and level of access to data to help you be as efficient as possible.

CrimpCloud® Basic
The easiest way to manage your crimp operations

	FEATURE	DESCRIPTION		BASIC	PLUS
REPORT	CERTIFICATE Crimper Calibration Report	Perform self-calibration, generate on-demand crimper calibration reports for your customer.	\$ 🏆	✓	✓
REPORT	Equipment Maintenance Management	Reduce downtime and extend longevity of your equipment.	\$	✓	✓
REPORT	Advanced Reporting	Improved inventory management.		✓	✓
REPORT	Equipment Utilization Dashboard	Comprehensive view of all equipment in one place.	\$	✓	✓
REPORT	Resource Management	Operational heat maps for resource and production management.		✓	✓
SOFTWARE	Automatic Data Backup	Crimper data backup.	\$	✓	✓
SOFTWARE	Priority Software Updates	Get new features and improvements before everyone else.		✓	✓
SUPPORT	Priority Equipment Support	CrimpCloud customers get priority response time.	\$	✓	✓
TRAINING	Training Resources	On demand video and tutorials, with yearly advanced webinars.	\$ 🏆 📺	✓	✓

CrimpCloud® Plus
The easiest way to track your hose assembly

	FEATURE	DESCRIPTION		BASIC	PLUS
TRACEABILITY	CrimpCloud® Labeling Software	Turnkey solution for hose traceability.	\$		✓
TRACEABILITY	Customizable Label	Your name, your logo.			✓
TRACEABILITY	Hose Birth Certificate	Unique ID generated for every hose assembly.	🏆		✓
TRACEABILITY	EXCLUSIVE Generate Unique ID from CrimpIQ Crimper	Label generated directly from the crimper at the time of crimp for improved quality control.	🏆		✓
TRACEABILITY	Universal Code System	Easy to read code with smart phone, no additional equipment needed.			✓
TRACEABILITY	Batch Coding	Generate labels for large orders in one print.			✓
TRACEABILITY	Access to CrimpCloud Database	Access to millions of assets in CrimpCloud database.			✓
TRACEABILITY	Bill of Material	Retrieve bill of material information.	🏆		✓
TRACEABILITY	Production Data Log	Access details on hose assembly fabrication.			✓
TRACEABILITY	Direct Replacement Ordering	Generate more revenue with replacement sales.	\$		✓

\$ SAVINGS/REVENUE 🏆 QUALITY 📺 TRAINING







CrimpCloud® Traceability

HYDRAULIC EQUIPMENT



CrimpCloud® Accessories



CrimpCloud® Accessories				
Type	SAP #	Description	Stock	MOQ
 BASIC	21147851	CrimpCloud® BASIC Annual Subscription	Y	1
 PLUS	21147852	CrimpCloud® PLUS Annual Subscription	Y	1
 ADD-ON	21147853	CrimpCloud® Crimper Add-On Annual Subscr.	Y	1
 RETROFIT	21117124	CrimpCloud® and CrimpIQ™ Retrofit Bundle	Y	1
	21197481	Zebra ZT231 Thermal Transfer Industrial Printer Resolution: 203 dpi print resolution (8 dots / mm) Maxium Print Width: 4" Connectivity: Serial USB Ethernet Bluetooth Wifi	Call	1
	21135991	CrimpCloud® Asset Label 2x6 (2250 MOQ) Heavy duty material. Designed to excel in the most challenging applications, including extreme temperatures, UV, submersion in many fluids. (Customs Code: 3919102040)	Y	2,250

Contact us for a Demo at crimpcloud@continental.com or visit crimpcloud.com.

Technical Specifications ZT231 Industrial Printer

Specifications are provided for reference and are based on testing the ZT231 printer using genuine Zebra® supplies. Results may vary in actual application settings or when using other-than-recommended Zebra supplies. Zebra recommends always qualifying any application with thorough testing.

STANDARD FEATURES

PRINTING

- Thermal transfer and direct thermal printing
- Thin film printhead with E3™ Element Energy™ Equalizer for superior print quality
- 203 dpi print resolution (8 dots / mm)
- Print speed per second up to 14" (356 mm / second)

COMMUNICATION

- USB 2.0, high speed
- RS-232 Serial (RS-232C with DB9F connector; Configurable baud rate (2400 - 115,200kb), parity, and data bits. Stop bits at 1 or 2; Software (XON/XOFF), hardware (DTR/DSR or RTS/CTS) communication handshake protocols)
- 10/100 Ethernet: Supports networks internally integrated option that enables the use of Webview and Alert features
- Bluetooth® 4.1 (including Apple®)
- Dual USB Host

OPERATION

- 4.3-inch color touch display with intuitive menu for quick operation and settings management
- Bi-colored status LEDs for quick printer status
- ARM Cortex A7 processor
- 256 MB RAM memory (8 MB User Available)
- 512 MB Flash memory (64 MB User Available)
- Print Touch™ application
- Link-OS®-enabled
- Auto-switching 100-240V power supply
- ENERGY STAR® qualified
- Printhead element out detection



MEDIA SUPPORT

- Dual media sensors – transmissive and reflective
- 3" media supply hanger
- Auto calibration when printer is turned on or when printhead is closed

DESIGN

- Easy, side-loading metal print mechanism
- Tool-less printhead and platen replacement
- Metal media cover with enlarged clear viewing window
- Robust-gold user touch points indicating key adjustments
- Bi-fold media door decreasing overall operating space by 35%

FIRMWARE

- Resident ZPL®, ZPL II® and EPL™ programming languages, selectable through software or front panel
- XML-Enabled Printing – allows XML communications for barcode label printing eliminating license fees and printer server hardware while lowering customization and programming costs



Continental has the right accessories for your facility.



HS-150 Series Hose Saw

The HS-150 hose saw is a rugged, compact, and lightweight engineered design ideal for small workshops with a low maintenance cost.

The HS-150 standard package includes: Serrated blade, hose bending pins, and 1 ¼" vacuum adapter.

FEATURES

- › Ideal for on-site service where electricity is not available
- › Compact design to fit in workshops and for on-site services



Vacuum port allows attachment of vacuum system to keep saw and work space clean.



Hose Bending Pins prevent the blade from binding during a cut.



Serrated blade is for general purpose and is recommended to cut multi-spiral hose.

HS-150 Series Hose Saw

CAPABILITY

- › The HS-150 is designed to cut 1- and 2-braid hydraulic hose up to 1 ½" ID and up to 1 ¼" 4-spiral hose

TECHNICAL DATA

WEIGHT 70 lbs. (hose saw only)

DIMENSIONS 28 ¾" L x 21" W x 12 ¼" H



AVAILABLE CONFIGURATIONS

SAP #	Voltage	Phase	Plug	Hertz	Country Approved	Serrated Blade Included	Hose Bending Pins Included	1¼" Vacuum Adapter Included
20614553	110V	1	NEMA 5-15	50/60	*CAN, MEX, USA	✓	✓	✓
20829262	12VDC	1	Jumper Cables	50/60	*CAN, MEX, USA	✓	✓	✓

*CSA rated components are being used, but CSA decal isn't applied.

HS-500 Series Hose Saw

The HS-500 hose saw is a rugged engineered design, and the accessories included make it the best value of any hose saw in its class with a low maintenance cost.

The HS-500 standard package includes: Serrated blade, hose helper, hose bending pins, and 1¼" vacuum adapter.

FEATURES

- › The HS-500 can be mounted on the HS-Mobile cart for easy moving around the shop
- › The Hose Channel System both measures and supports the hoses up to 2 inch diameter as they are being cut



The mister sprays a fine mist of air tool oil on the saw blade for longer blade life and cleaner cuts.



Hose bending pins prevent the blade from binding during a cut.



Hose helper attachment prevents the hose from being drawn back during a cut.



A resettable counter makes it easy to keep track of the number of cuts made.



Vacuum port allows attachment of vacuum system to keep saw and work space clean.

HS-500 Series Hose Saw

CAPABILITY

- › The HS-500 is designed to cut 1- and 2-braid hydraulic hose up to 2" ID and up to 2" 4- or 6-spiral hose.

TECHNICAL DATA

WEIGHT 120 lbs. (hose saw only)

DIMENSIONS 29 ¾" L x 26 ¾" W x 16" H



AVAILABLE CONFIGURATIONS

SAP #	Voltage	Phase	Plug	Hertz	Country Approved	Serrated Blade Included	Hose Helper Included	Hose Bending Pins Included	1¼" Vacuum Adapter Included
20614557	230V	1	NEMA L6-30	60	*CAN, MEX, USA	✓	✓	✓	✓
20614556	230V	3	NEMA L15-20P	60	*CAN, MEX, USA	✓	✓	✓	✓
21095955	480V	3	NEMA L16-20P	60	*CAN, MEX, USA	✓	✓	✓	✓

*CSA rated components are being used, but CSA decal isn't applied.

Hose Reel Rack Series

The Hose Reel Rack is designed to keep the hose spools organized and secure, is made of heavy-duty steel and comes in 2 compact designs (24" and 36" wide) to accommodate your needs.



FEATURES

KEEP HOSE SPOOLS ORGANIZED

- › 5 different positions for customizable configurations that fit various sized hose spools
- › 2 reel holders for 2 larger hose spools, or 3 reel holders for 3 smaller hose spools
- › 3 reel holders are included (additional reels are available)
- › Easy installation, hardware included



Compact design for minimum use of space.



You can customize your sized hose spools that best fit your needs.



Hose reel rack keeps the hose spools organized and clean.

Hose Reel Rack Series

2 COMPACT MODELS AVAILABLE

- › 24" W Hose Reel Rack
- › 36" W Hose Reel Rack

TECHNICAL DATA

HOSE CAPACITY

600 lbs. (24" and 36" Hose Reel Racks)

DIMENSIONS

24" Hose Reel Rack

36" L x 30" W x 72 1/4" H

36" Hose Reel Rack

36" L x 42" W x 72 1/4" H

WEIGHT

24" Hose Reel Rack

119 lbs.

36" Hose Reel Rack

128 lbs.

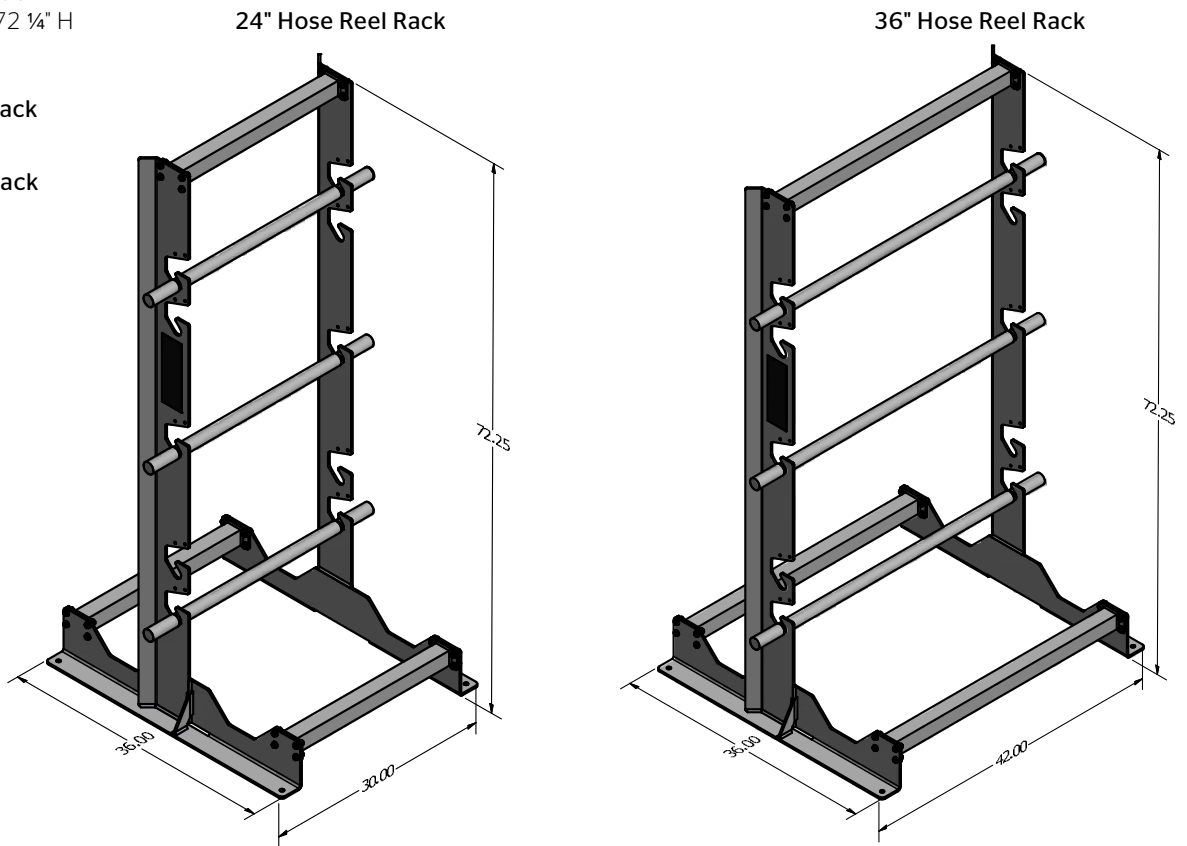

AVAILABLE CONFIGURATIONS

SAP #	Hose Reel Rack Model	Powder Coat	3 Reel Holders Included	Hardware Included
21024821	24" W Hose Reel Rack	Black	✓	✓
21024823	36" W Hose Reel Rack	Black	✓	✓

CC-FP10 Series Fitting Pusher

The CC-FP10 Series fitting pusher is an essential tool for any workshop producing industrial hose assemblies. The 10 ton hydraulic cylinder with an 18" stroke takes the time consuming and difficult task of installing industrial fittings on large hoses and makes it quick, simple, and safe. Easy portability means that you can take the CC-FP10 right to the job and quickly install fittings on hoses from 2 to 12 inches in diameter.

The CCFP-10 standard package includes: 2" strap w/ flat hook, 1 1/8" wrench, elbow fitting adapter, and pusher spacers.

FEATURES

EASY OPERATING SYSTEM

- › 10 tons of available force
- › Easy installing fittings on hoses from 2" to 12" diameter
- › Easy tie down and quick release system



Flexible tie down system securely grips hoses from 2 to 12 inches in diameter.



Quick tightening using the wrench and quick release using the quick release pedals.



10 tons of available force.

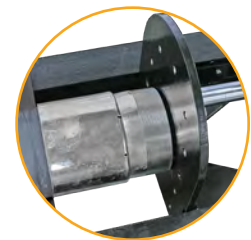

Fitting pusher makes inserting industrial fittings faster and safer.



Elbow fitting adapter and the ability to adjust the position of the ram makes it possible to assemble a wide variety of fittings.



Quick release pedals to release the tie down straps.

CC-FP10 Series Fitting Pusher

CAPABILITY

- › 10 ton (with 18" stroke)
- › Fitting insertion on hoses up to 12" diameter

TECHNICAL DATA

WEIGHT 465 lbs.

DIMENSIONS 91 ½" L x 29" W x 24 ⅝" H



AVAILABLE CONFIGURATIONS

SAP #	Voltage	Phase	Plug	Hertz	Country Approved	Elbow Fitting Adapter Included	2" Strap w/Flat Hook Included	11/8" Wrench Included
20621100	110V	1	NEMA 5-15	60	*CAN, MEX, USA	✓	✓	✓
20798076	220V	1	NEMA 6-20	60	*CAN, MEX, USA	✓	✓	✓

*CSA rated components are being used, but CSA decal isn't applied.

Crimper Spare Part Kits

PC125RCD-SPK

SAP# 21053593

Kit Includes:



(2) 4oz Bottles of CrimpX Oil



(1) Die Removal Magnet



(1) Continental Notched Caliper

PC125-SPK

SAP# 21053592

Kit Includes:



(2) 4oz Bottles of CrimpX Oil



(1) PC125 Black Die Ring (Half)



(8) PC125 Die Screws



(8) PC125 Die Springs

PC150/PC160i-SPK

SAP# 21053594

Kit Includes:



(2) 4oz Cans of CrimpX Grease



(1) PC150 Black Die Ring (Half)



(8) PC150 Die Screws



(8) PC150 Die Springs

PC150H-SPK

SAP# 21053595

Kit Includes:



(1) 3oz Mini Gun Tube of CrimpX Grease



(4) PC150H Foam Pads



(8) PC150H Die Studs



(8) QCT Pins

PC150HD-SPK

SAP# 21099232

Kit Includes:



(1) 14oz Large Tube of CrimpX Grease



(4) PC150HD Foam Pads



(8) PC200 Die Studs



(8) QCT Pins

PC200-SPK

SAP# 21053596

Kit Includes:



(1) 14oz Large Tube of CrimpX Grease



(4) PC200 Foam Pads



(8) PC200 Die Studs



(8) QCT Pins

PC400-SPK

SAP# 21053597

Kit Includes:



(1) 14oz Large Tube of CrimpX Grease



(4) PC400 Foam Pads



(8) PC200 Die Studs



(4) PC400 Die Studs



(8) QCT Pins

Continental Calipers

Bluetooth and Notched

FEATURES

BLUETOOTH The CrimpIQ™ Controller supports the bluetooth caliper to input crimp diameter measurements. This integration saves time and reduces the chance that the measurements are incorrectly entered.

NOTCHED This caliper is great for measuring small crimp flats and AC style crimps.

SAP #	Description
21021158	Continental Bluetooth Digital Caliper (in./mm) - Compatible only with CrimpIQ™ Controller
20926931	Continental Notched Digital Caliper (in./mm)



Bluetooth Caliper



Notched Caliper

Die Series

PC125

Compatible with: PC125M, PC125

SAP #	Description	Color	ID
20244896	PC125-8.5MM	Black	8.5 mm
20244897	PC125-12MM	Black	12 mm
20244898	PC125-14MM	Red	14 mm
20244899	PC125-16MM	Blue	16 mm
20244920	PC125-19MM	Green	19 mm
20244921	PC125-23MM	Yellow	23 mm
20244922	PC125-27MM	Brown	27 mm
20244923	PC125-31MM	Silver	31 mm
20244924	PC125-34MM	Purple	34 mm
20244925	PC125-41MM	Orange	41 mm
20867524	PC125-43MM	Black	43 mm
20244927	PC125-50MM	Black	50 mm

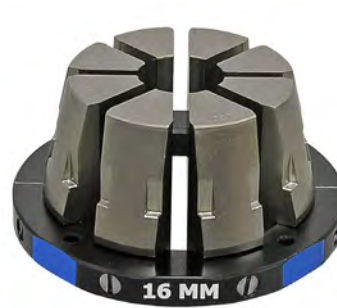

PC125 Die Screw
SAP # 20244928



PC125 Die Spring
SAP # 20244929

SAP #	Description	Color	Etch
21095958	PC125 Die Ring Half	Black	8.5MM
21095957	PC125 Die Ring Half	Black	12MM
20370767	PC125 Die Ring Half	Red	14MM
20370760	PC125 Die Ring Half	Blue	16MM
20370748	PC125 Die Ring Half	Green	19MM
20370772	PC125 Die Ring Half	Yellow	23MM
20370761	PC125 Die Ring Half	Brown	27MM
20370762	PC125 Die Ring Half	Silver	31MM
20370763	PC125 Die Ring Half	Purple	34MM
20370765	PC125 Die Ring Half	Orange	41MM
20918174	PC125 Die Ring Half	Red	43MM
20918175	PC125 Die Ring Half	Black	45MM
20918176	PC125 Die Ring Half	Black	50MM
20370778	PC125 Die Ring Half	Black	None

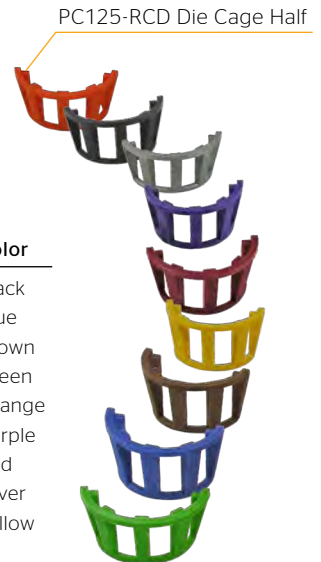

PC125RCD

Compatible with:

PC100-RCD, PC125M-RCD, PC125-RCD, PC125PS

SAP #	Description	Color	ID
20833010	PC125RCD-8.5MM	Black	8.5 mm
20833011	PC125RCD-12MM	Black	12 mm
20833012	PC125RCD-14MM	Red	14 mm
20809576	PC125RCD-16MM	Blue	16 mm
20809577	PC125RCD-19MM	Green	19 mm
20809578	PC125RCD-23MM	Yellow	23 mm
20809579	PC125RCD-27MM	Brown	27 mm
20809760	PC125RCD-31MM	Silver	31 mm
20809761	PC125RCD-34MM	Purple	34 mm
20809762	PC125RCD-41MM	Orange	41 mm
20899115	PC125RCD-43MM	Red	43 mm
20833014	PC125RCD-50MM	Black	50 mm

SAP #	Description	Color
20833017	PC125-RCD Die Cage Half	Black
20833018	PC125-RCD Die Cage Half	Blue
20833019	PC125-RCD Die Cage Half	Brown
20833020	PC125-RCD Die Cage Half	Green
20833021	PC125-RCD Die Cage Half	Orange
20833022	PC125-RCD Die Cage Half	Purple
20833023	PC125-RCD Die Cage Half	Red
20833024	PC125-RCD Die Cage Half	Silver
20833025	PC125-RCD Die Cage Half	Yellow

Die Series

PC120M

SAP #	Description	Color	ID
21163020	PC120-08 MM DIE	Black	08 mm
21163021	PC120-10 MM DIE	Black	10 mm
21163022	PC120-12 MM DIE	Black	12 mm
21163023	PC120-14 MM DIE	Red	14 mm
21163024	PC120-16 MM DIE	Blue	16 mm
21163039	PC120-19 MM DIE	Green	19 mm
21163025	PC120-23 MM DIE	Yellow	23 mm
21163026	PC120-27 MM DIE	Brown	27 mm
21163027	PC120-31 MM DIE	Silver	31 mm
21163028	PC120-37 MM DIE	Black	37 mm



PC120M Die Carrying Case



Die Identification Chart

PC120M Die Kit:
16mm, 19mm, 23mm,
27mm, 31mm, 37mm

Colored Die Size Decals

Crimping Accessories

Die Compartments for additional dies

Die Series

PC160i

Compatible with: PC160i, PC150

SAP #	Description	Color	ID
20244949	PC150-8.5MM	Black	8.5 mm
20244950	PC150-12MM	Black	12 mm
20244951	PC150-14MM	Red	14 mm
20244952	PC150-16MM	Blue	16 mm
20244953	PC150-19MM	Green	19 mm
20244954	PC150-23MM	Yellow	23 mm
20244955	PC150-27MM	Brown	27 mm
20244956	PC150-31MM	Silver	31 mm
20244957	PC150-34MM	Purple	34 mm
20244958	PC150-41MM	Orange	41 mm
20244959	PC150-45MM	Black	45 mm
20244960	PC150-50MM	Black	50 mm
20244961	PC150-56MM	Black	56 mm

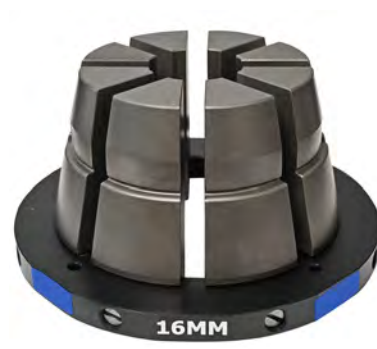

PC150/PC160i Die Screw
SAP # 20244962



PC150/PC160i/
PC150 DA Die Spring
SAP # 20244963

SAP #	Description	Color	Etch
21095962	PC150 Die Ring Half	Black	8.5MM
21095959	PC150 Die Ring Half	Black	12MM
20688964	PC150 Die Ring Half	Blue	16MM
20704273	PC150 Die Ring Half	Green	19MM
20704275	PC150 Die Ring Half	Yellow	23MM
20455159	PC150 Die Ring Half	Brown	27MM
20543412	PC150 Die Ring Half	Silver	31MM
20466009	PC150 Die Ring Half	Purple	34MM
20495092	PC150 Die Ring Half	Orange	41MM
21095960	PC150 Die Ring Half	Black	45MM
20646846	PC150 Die Ring Half	Black	50MM
21095961	PC150 Die Ring Half	Black	56MM



PC150/PC160i Die Ring Half

Blue Decal

Etch

PC160i Wide Body

Compatible with: PC160i

SAP #	Description	Color	ID
21188164	PC160i-49 MM WB Die	Black	49 mm
21188165	PC160i-53 MM WB Die	Black	53 mm
21188166	PC160i-58 MM WB Die	Black	58 mm
21188167	PC160i-62 MM WB Die	Black	62 mm
21188168	PC160i-65 MM WB Die	Black	65 mm
21188169	PC160i-69 MM WB Die	Black	69 mm
21188220	PC160i-74 MM WB Die	Black	74 mm



PC160i WB Die Screw
SAP # 21189475



PC160i WB Die Spring
SAP # 21189474

SAP #	Description	Color
21189473	PC160i Blank Replacement Die Ring Half	Black



PC160i Blank Replacement Die Ring Half

Die Series

PC150 Double Angle¹

Compatible with: PC150

SAP #	Description	Color	ID
20294365	49MM X 85MM	Black	49 mm
20294366	53MM X 108MM	Black	53 mm
20294367	58MM X 108MM	Black	58 mm
20294368	62MM X 108MM	Black	62 mm
20294369	69MM X 85MM	Black	69 mm
20294480	74MM X 108MM	Black	74 mm
20294481	78MM X 108MM	Black	78 mm
20951074	52MM X 108MM	Black	52 mm
21061269	56MM X 108MM	Black	56 mm



PC150 DA Die Screw
SAP # 21095557



PC150/PC150 DA
Die Spring
SAP # 20244963

¹ PC150 Double Angle dies standard length are 78MM long and INH dies are 110MM long.

Die Series

PC150H

Compatible with: PC150H, PC150HD, PC150HDX

SAP #	Description	Color	ID
20316414	PC150H-8.5	Black	8.5 mm
20316415	PC150H-12	Black	12 mm
20316416	PC150H-14	Red	14 mm
20316417	PC150H-16	Blue	16 mm
20316418	PC150H-19	Green	19 mm
20316419	PC150H-23	Yellow	23 mm
20316420	PC150H-27	Brown	27 mm
20316421	PC150H-31	Silver	31 mm
20316422	PC150H-34	Purple	34 mm
20316423	PC150H-41	Orange	41 mm
20316424	PC150H-45	Black	45 mm
20316425	PC150H-50	Black	50 mm
20644520	PC150H-53	Black	53 mm
20316426	PC150H-56	Black	56 mm



PC200 Die Lock Stud
SAP # 20269407

PC200

Compatible with: PC200, PC200i, PC400, PC400i, PC440, PC440i, PC600L, PC600i, PC1000, PC1000i, PC1200, PC1200i

SAP #	Description	Color	ID
20244973	PC200-8.5MM	Black	8.5 mm
20244974	PC200-12MM	Black	12 mm
20244975	PC200-14MM	Red	14 mm
20244976	PC200-16MM	Blue	16 mm
20244977	PC200-19MM	Green	19 mm
20244978	PC200-23MM	Yellow	23 mm
20244979	PC200-27MM	Brown	27 mm
20244980	PC200-31MM	Silver	31 mm
20244981	PC200-34MM	Purple	34 mm
20244982	PC200-41MM	Orange	41 mm
20244983	PC200-45MM	Black	45 mm
20244984	PC200-50MM	Black	50 mm
20646528	PC200-53MM	Black	53 mm
20244985	PC200-56MM	Black	56 mm
20244986	PC200-62MM	White	62 mm
20244987	PC200-69MM	Pink	69 mm
20244988	PC200-74MM	Lime	74 mm
21099231	PC200-76MM	Black	76 mm
20249890	PC200-78MM	Orange	78 mm



PC200 Die Lock Stud
SAP # 20269407

Die Series

PC600i

Compatible with: PC440, PC440i, PC600L, PC600Li

SAP #	Description	ID
20673573	PC600-84MM	84 mm
20685703	PC600-86MM	86 mm
20742520	PC600-89MM	89 mm
20685704	PC600-90MM	90 mm
20673574	PC600-92MM	92 mm
20673575	PC600-100MM	100 mm
20673576	PC600-108MM	108 mm
20802397	PC600-114MM	114 mm
20673577	PC600-116MM	116 mm
20685705	PC600-118MM	118 mm
20258403	PC600-122MM	122 mm
20673578	PC600-126MM	126 mm
20562654	PC600-166MM	166 mm
20562655	PC600-178MM	178 mm



PC200 Die Lock Stud
SAP # 20269407



PC440/PC600/
PC600L/PC1000
Master Die Lock Stud
SAP # 20776806

PC1000i

Compatible with: PC600, PC600i, PC1000, PC1000i

SAP #	Description	ID
20562098	PC600-84MM	84 mm
20562099	PC600-92MM	92 mm
20562650	PC600-100MM	100 mm
20562651	PC600-108MM	108 mm
20562652	PC600-116MM	116 mm
20562653	PC600-126MM	126 mm



PC200 Die Lock Stud
SAP # 20269407



PC1000
Master Die Lock Stud
SAP # 20776808

PC1000i

Compatible with: PC1000, PC1000i

SAP #	Description	ID
20590712	PC1000-166MM	166 mm
20590713	PC1000-178MM	178 mm
20708157	PC1000-190MM	190 mm
20590714	PC1000-215MM	215 mm
20590715	PC1000-245MM	245 mm



PC440/PC600/
PC600L/PC1000
Master Die Lock Stud
SAP # 20776806



PC1000 Master
Die Lock Stud
SAP # 20776807

Die Series

PC1200i

Compatible with: PC1200i

SAP #	Description	ID
20818690	PC1200-155MM	155 mm
20828458	PC1200-166MM	166 mm
20828459	PC1200-178MM	178 mm
20775367	PC1200-245MM	245 mm
20818691	PC1200-260MM	260 mm
20828650	PC1200-275MM	275 mm
20775368	PC1200-281MM	281 mm



PC200 Die Lock Stud
SAP # 20269407



PC1200i Die Lock Pin
For Adapter Dies
& Industrial Dies Series
SAP # 21099179



PC1200i Die Lock Pin
For Adapter Dies
& Industrial Dies Series
SAP # 21099230

AC Die Series

PC125-AC

Compatible with: PC125M, PC125

SAP #	Description	Color	ID
20341146	PC125-AC06	Black	.551 in
20341147	PC125-AC08	Black	.728 in
20341148	PC125-AC12	Black	.885 in



PC125 Die Screw
SAP # 20244928



PC125 Die Spring
SAP # 20244929

PC125RCD-AC

Compatible with: PC100-RCD, PC125M-RCD, PC125-RCD, PC125PS

SAP #	Description	Color	ID
20833026	PC125RCD-AC06	Orange	.551 in
20833027	PC125RCD-AC08	Orange	.728 in
20833028	PC125RCD-AC12	Orange	.880 in



PC150-AC

Compatible with: PC150

SAP #	Description	Color	ID
20341547	PC150-AC06	Black	.551 in
20341548	PC150-AC08	Black	.728 in
20341549	PC150-AC12	Black	.885 in



PC150 Die Screw
SAP # 20244962



PC150/PC150 DA
Die Spring
SAP # 20244963

PC150H-AC

Compatible with: PC150H, PC150HD

SAP #	Description	Color	ID
20345080	PC150H-AC06	None	.551 in
20345081	PC150H-AC08	None	.728 in
20345082	PC150H-AC12	None	.885 in



PC200 Die Lock Stud
SAP # 20269407

PC200-AC

Compatible with: PC200, PC200i, PC400, PC400i, PC440, PC440i, PC600L, PC600i, PC1000, PC1000i, PC1200, PC1200i

SAP #	Description	Color	ID
20825493	PC200-AC04	None	.472 in
20345083	PC200-AC06	None	.551 in
20345084	PC200-AC08	None	.728 in
20345085	PC200-AC12	None	.885 in



PC200 Die Lock Stud
SAP # 20269407

PC150H and PC200 Die Decal Replacement Kit

SAP # 20923531

The PC150H die decal kit includes (8) pieces die decal of each of the following die sizes 16mm, 19mm, 23mm, 27mm, 31mm, 34mm, 41mm, 45mm, 50mm, 53mm, 59mm, 62mm, 74mm, 78mm plus (8) PC200 die studs.



PC150H and PC200 Die Series Individual Decals



8.5 mm Black
8 Piece Die Decal
SAP # 20922986



12 mm Black
8 Piece Die Decal
SAP # 20922960



14 mm Red
8 Piece Die Decal
SAP # 20922961



16 mm Blue
8 Piece Die Decal
SAP # 20922962



19 mm Green
8 Piece Die Decal
SAP # 20922963



23 mm Yellow
8 Piece Die Decal
SAP # 20922964



27 mm Brown
8 Piece Die Decal
SAP # 20922965



31 mm Silver
8 Piece Die Decal
SAP # 20922966



34 mm Purple
8 Piece Die Decal
SAP # 20922967



39 mm Orange
8 Piece Die Decal
SAP # 21095963



41 mm Orange
8 Piece Die Decal
SAP # 20922968



45 mm Black
8 Piece Die Decal
SAP # 20922969



50 mm Black
8 Piece Die Decal
SAP # 20922980



56 mm Black
8 Piece Die Decal
SAP # 20922981



57 mm Black
8 Piece Die Decal
SAP # 21095964



59 mm Black
8 Piece Die Decal
SAP # 21095965

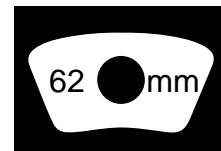

62 mm White
8 Piece Die Decal
SAP # 20922982



63 mm White
8 Piece Die Decal
SAP # 21095966



69 mm Pink
8 Piece Die Decal
SAP # 20922983



74 mm Lime
8 Piece Die Decal
SAP # 20922984



78 mm Orange
8 Piece Die Decal
SAP # 20922985

Replacement Parts

Insertion Blocks



SG Insertion Block
SAP # 21061267



B2 Insertion Block
SAP # 20828658



SIAB Insertion Block Assembly
SAP # 21157981

CrimplQ™ Controller



CrimplQ™ 10 inch tablet
SAP # 21021149



CrimplQ™ Caliper Dongle
SAP # 21021153

Removable Pushers / Pusher Retaining Pins



PC100 Pusher
Removable Pusher with Magnets
SAP # 20244918
Removable Pusher without Magnets
SAP # 20244933



PC100RCD/PC125 Pusher
Removable Pusher with Magnets
SAP # 20348434
Removable Pusher without Magnets
SAP # 20551881



PC150/PC160i Pusher
Removable Pusher without Magnets
SAP # 20244946



PC100/PC125 Pusher Retaining Pin
SAP # 20291768



PC150/PC160i Pusher Retaining Pin
SAP # 20419989

Replacement Parts

Pressure Plates



PC100 Series
Pressure Plate
SAP # 20244935



PC125 Series
Pressure Plate
SAP # 20395217



PC150 Series
Pressure Plate
SAP # 20244948



PC150 Series
Double Angle Base
SAP # 20294363



PC160i Series
Pressure Plate With
Die Retention Plate
SAP # TBA



PC160i Series
WB Press Plate
SAP # 21195467

T420 Pressure Plates



PC100RCD Series
T420 Pressure Plate
SAP # 21095967



PC100RCD Series
T420 Notched Pressure Plate
SAP # 21095968



PC125RCD Series
T420 Pressure Plate
SAP # 20833015



PC125RCD Series
T420 Notched Pressure Plate
SAP # 20867520

Spacer Kits



PC125 Spacer Kit
for use with extra
long elbow fittings
SAP # 20287002



PC150 Spacer Kit
for use with extra
long elbow fittings
SAP # 20244965

Replacement Parts

Compression Rings



PC100 Series
Compression Ring
SAP # 20244934



PC100 Series
Notched Compression Ring
SAP # 20348935



PC125 Series
Compression Ring
SAP # 20470304



PC125 Series
Notched Pressure Plate
SAP # 20348513



PC150/PC160i Series
Compression Ring
SAP # 20244947



PC150 Series
Double Angle Top
SAP # 20294364

Die Storage Shelves and Racks



PC125 Stand / Drawer
SAP # 20244895



PC150 Die Shelf
SAP # 20244943



PC150H Die Rack 9 Stations
PC150H Die Series SAP # 20316458
PC200 Die Series SAP # 20406017



PC200 Rack Stand 16 Stations
PC200 Die Series SAP # 20244970



Industrial Die Compartment
SAP # 21095971



Fitting Cabinet CB101
SAP # 20240780

OPTIONS

SAP #	Part #	Description
20240781	CB200	Set of 5 large (7 ¾") plastic bins
20240782	CB201	Set of 10 small (3 ¼") plastic bins
20240784	CB301	Set of stationary legs (Bolt-on with pre-drilled holes)

Replacement Parts

Die Lubricant



Mini Grease Gun w/ CRIMPX Die Lubricant 3 oz mini grease tube
SAP # 21095969



14 oz Grease Gun w/ CRIMPX Die Lubricant 14 oz large grease tube
SAP # 21095970



CRIMPX Die Lubricant 3 oz mini grease tube
SAP # 20244993



CRIMPX Die Lubricant 14 oz large grease tube
SAP # 20828391



CRIMPX Lubricant Grease 4 oz can with brush
SAP # 20828390



CRIMPX Lubricant Grease 16 oz can with brush
SAP # 20244994



CRIMPX Die Lubricant Oil: 4 oz bottle with dauber cap
SAP # 20708983



PC900 Aerosol Lube Dry-Moly
SAP # 20244995

Die Removal Tools



Die Removal Magnet
PC100/PC125/PC150
SAP # 20934196



Quick Change Tool
PC150H Die Series SAP # 20319405
PC200 Die Series SAP # 20267266



Intermediate Die Removal Tool
PC200i/PC400i
SAP # 20415012



Intermediate Die Removal T-Handle Hex
PC440i/PC600i/PC1000i/PC1200i
SAP # 21095975

Replacement Parts

Foot Switches



Foot Switch w/ Guard
Touch Screen Crimpers
SAP # 21095974



Foot Switch w/ Guard
Dial Micrometer Crimpers
SAP # 21095973



Foot Switch Only
Touch Screen Crimpers
SAP # 20553044



Start / Stop Switch
1-2 HP Pumps
SAP # 20244945

Adjustable Coupling Stops and Manual/Electric Back Stops



PC125 Coupling Stop
SAP # 20244936



PC150 Coupling Stop
SAP # 20244944



PC150H Manual Back Stop
SAP # 21095976



PC200-MBS Manual Back Stop
SAP # 20244971



PC200-EBS Electric Back Stop
SAP # 20244972

Replacement Parts

Micrometers



T420 Micrometer
PC100/PC125
SAP # 20833016



Metric Micrometer
PC100/PC125/PC150
SAP # 20370791



Dial Micrometer
PC150H SAP # 20628361
PC150HD SAP # 21095977
PC200M SAP # 21095978

Protective Master Die Foam Pads



Protective Master Die Foam Pad
PC150H SAP # 20419636



Protective Master Die Foam Pad
PC150HD SAP # 21095979



Protective Master Die Foam Pad
PC200 SAP # 20419635



Protective Master Die Foam Pad
PC400 SAP # 20419639

Replacement Parts

Die Springs and Screws



PC125 Die Spring
SAP # 20244929



PC125 Die Screw
SAP # 20244928



PC150/PC160i/PC150 DA Die Spring
SAP # 20244963



PC150/PC160i Die Screw
SAP # 20244962



PC150 DA Die Screw
SAP # 21095557



PC160i WB Die Spring
SAP # 21189474



PC160i WB Die Screw
SAP # 21189475

Die Lock Studs



PC200 Die Lock Stud
SAP # 20269407



PC400 Die Lock Stud
SAP # 20276754



PC440 Die Lock Stud
SAP # 21038385



PC1200i Die Lock Stud
SAP # 21099179



PC1200i Die Lock Stud
SAP # 21099230

Master Die Lock Studs



PC1000 Master Die Lock Stud
SAP # 20776808



PC440/PC600/PC600L/PC1000
Master Die Lock Stud
SAP # 20776806



PC1000 Master Die Lock Stud
SAP # 20776807

Replacement Parts

Hose Saw Blades and Accessories

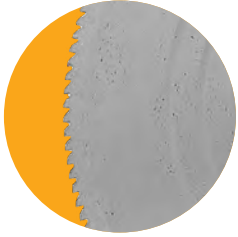

Serrated Blade
HS-150 SAP # 20683699
HS-500 SAP # 20922988



Scalloped Blade
HS-150 SAP # 21095980
HS-500 SAP # 20683700

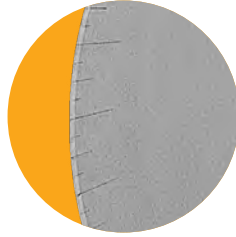

Double Bevel w/SS Slots Blade
HS-150 SAP # 20804794
HS-500 SAP # 21095981



HS-500 Mobile Cart
HS-500 SAP # 21095982



Hose Helper
HS-500 SAP # 21095983



Mister Hose Assembly
HS-500 SAP # 21095984



Hose Channel System (5ft)
HS-500 SAP # 21095985



Hose Bending Plns
HS-150/HS-500 SAP # 21095986

Hand, Pneumatic, Electric Pumps



PC100 Hand Pump
SAP # 21095988



PC125-HPump Hand Pump
PC125M SAP # 20244931



PC125-PPump Pneumatic Pump
PC100/125M SAP # 20244932



PC125M Portable Power Unit
110V / 3/4HP
SAP # 20244916

Ultra Clean Products



Bench Mount Launcher
SAP # 21187423



1-1/4" Hand Held Launcher
SAP # 21187687



2" Hand Held Launcher
SAP # 21187692



Nozzle Holder
SAP # 21187449



Production clean seal system
SAP # 21187670



Heat shrink gun and starter kit
SAP # 21187673



Capsule dispenser kit
SAP # 21187678



1/4 thru 1-1/4" projectile starter kit
SAP # 21187522



1/4 thru 2" projectile starter kit
SAP # 21187523



Projectile catcher bucket
SAP # 21187445

Ultra Clean Products



Heat shrink gun and starter kit



CT-EL-8-DP Kit



Nozzle Holder

PC125/PC150/PC160i/150HD UC Starter Kit SAP # 21188221



Heat shrink gun and starter kit



CT-CAP Kit



Nozzle Holder

PC200M/PC200i/PC440i UC Starter Kit SAP # 21188222

For more information on Ultra Clean Products, please refer to Ultra Clean Product Brochure.

Electrical Plug Configuration Equipment

Crimper Power Cord - Plug Ends / Electrical Receptacle Outlet Requirements

The following Crimper Cords are supplied as standard with the purchase of the associated Crimper Voltage - Phase combination from Continental.

U.S.A.

110V 15A Grounding Plug
NEMA 5-15



U.S.A.

220V 20A 1PH Grounding Plug
NEMA 6-20



U.S.A.

30A 250V 1PH Grounding Plug
NEMA L6-30P



U.S.A.

20A 250V 3PH Grounding Plug
NEMA L15-20P



U.S.A.

20A 480V 3PH Grounding Plug
NEMA L1620P



Canada

30A 250V 3PH Grounding Plug
NEMA L1530P



Preventative Maintenance Package for Crimpers

Continental's preventative maintenance program for PC200/400/440/600/600L/1000 series crimpers is an annual service which keeps your crimper cleaned, calibrated, and running in peak performance. This service includes the cleaning of main wear components, inspection of wear components and seals, and calibration of your crimper. Prevent downtime with this economical service package performed at your facility.

We hope that our services will help eliminate downtime, shipping costs, and uncertainty of when your machine will be fixed. Please feel free to contact us to know more about the preventative maintenance package for your crimper.



Inspection of Potentiometer Bracket Assembly



New Grease Applied on All Wear Surfaces



Available CrimpIQ™ Controller Upgrade



Crimper Calibration



Inspection of Electrical Components

Crimper Calibration Services

Continental realizes how important crimper calibration is to your customer requirements. We offer yearly onsite calibration services to your crimping equipment for a nominal fee. Make sure you are compliant with your customers' standards and schedule your crimper calibration today.



		<h2>Continental Crimper Calibration</h2>	
1. Place the adapter die set in 1 thru 8 clockwise order.			
2. Place the calibration die set into the adapter dies in 1 thru 8 clockwise order.			
3. Perform onsite calibration of calipers with gage pins.			
Gage Pin Diameter	0.4987" ±	Gage Pin Diameter	0.877" ±
Pre-Calibration Center Crimp Details			

CLASSIC PC125M Series

CAPABILITY

- › (-20) B2 Fittings
- › (-16) SG Fittings

TECHNICAL DATA

- CRIMPING FORCE** 60 ton
- WEIGHT** 72 lbs. (crimper only)
- DIMENSIONS** 17" L x 10 ¼" W x 11" H
- DIE SERIES** PC125



AVAILABLE CONFIGURATIONS

SAP #	Pump	PSI	Reservoir Capacity	Country Approved	Dies Included	Die Sizes (mm)	Quick Disconnect Included	Drawer/Stand Included
20244937	*None	N/A	N/A	CAN, MEX, USA	8	16, 19, 23, 27, 31, 34, 43, 50	✓	✓
20244894	*None	N/A	N/A	CAN, MEX, USA	None		✓	

*Do not forget to buy your pump that best fits your portable crimping requirements. Refer to optional pump options (pump only) chart on page 25.

CLASSIC PC125 Series

CAPABILITY

- › (-20) B2 Fittings
- › (-16) SG Fittings

TECHNICAL DATA

- CRIMPING FORCE** 60 ton
- WEIGHT** 140 lbs. (crimper only)
- DIMENSIONS** 22 ½" L x 13" W x 22 ½" H
- DIE SERIES** PC125
- OIL CAPACITY** 1 gallon



AVAILABLE CONFIGURATIONS

SAP #	Pump	Phase	Plug	Hertz	Country Approved	Dies Included	Die Sizes (mm)	Drawer/Stand Included
20244940	110V	1	NEMA 5-15	60	CAN, MEX, USA	8	16, 19, 23, 27, 31, 34, 43, 50	✓
20913958	12VDC	1	Jumper Cables	N/A	CAN, MEX, USA	8	16, 19, 23, 27, 31, 34, 43, 50	✓
20244938	110V	1	NEMA 5-15	60	CAN, MEX, USA	None		

FHS - Fluid Handling Solutions

Market segment

Hydraulic Hose

Contact

Continental

703 S. Cleveland Massillon Road

Fairlawn, OH 44333-3023 U.S.A.

1-800-235-4632

www.continental-industry.com

Your local contact

www.contitech.de/contactlocator

Canada

1-888-275-4397

Mexico

1-800-439-7373



The content of this publication is not legally binding and is provided as information only. The trademarks displayed in this publication are the property of Continental AG and/or its affiliates. Copyright © 2021 ContiTech AG. All rights reserved. For complete information go to: www.contitech.de/discl_en